

OWNER'S MANUAL



PAR-650

5 Band Paraphic EQ



INTRODUCTION

Thank you for choosing *PrecisionPower™* audio equipment. At *PrecisionPower™* we proudly design and engineer the world's finest audio products. Our award winning products utilize innovative design and technology to consistently deliver ***Absolutely State of the Art™*** performance, sound quality, reliability, and value. This *PrecisionPower™* product reflects our commitment to offer you unparalleled versatility and quality for years of dependable service and listening enjoyment.

SERVICE

Do not attempt to service *PrecisionPower™* products yourself. Performing exploratory surgery on your audio equipment yourself will void the warranty. Many parts of your *PrecisionPower™* gear are custom built to our specifications. Our factory parts are not made available to anyone else nor are they for sale. Our goal is to make sure that your *PrecisionPower™* product will always sound as good as the day it was purchased. Contact your authorized *PrecisionPower™* dealer about obtaining any warranty service through *PrecisionPower™*. (See Warranty inside back cover.)

Model: _____

Serial Number: _____

Date of Purchase: _____

CAUTION

High-powered car audio systems may produce sound pressure levels that exceed the threshold at which hearing loss may result. They may also impair a driver's ability to hear traffic sounds or emergency vehicles. Use common sense and practice safe listening habits when listening to or adjusting your audio system.

FEATURES/SPECIFICATIONS

- 18dB boost/cut filters with adjustable center frequencies.
- Dual function controls pull out for easy system tuning.
- Separately adjustable front and rear high-pass crossovers.
- Dedicated subwoofer output with adjustable low-pass crossover.
- Front panel controls for fader, sub level, and HP/LP frequencies.
- Master volume control drives over 10 volts RMS output (sub out).
- Three switched inputs for controlling multiple sources.
- Selectable dual color illumination and backlit controls.

- Built-in remote output with turn-on delay for switching on amps.
- 30V MOSFET switching power supply.
- Gold-plated RCA input/output jacks.
- Half-din chassis for ease of installation.

INSTALLATION

1. Read this manual carefully and in its entirety before installing this equalizer.
2. Always disconnect the battery or remove the fuses for circuits you will be working on.
3. Check for clearance of any hazards such as wiring harnesses or heater core before mounting the equalizer to any panels in the vehicle.
4. Mount the equalizer in a location that is easy to access and won't be distracting to vehicle operation while making adjustments.
5. Route all power wires and audio cables away from sharp metal edges that can cause shorts to ground and any moving parts that can tangle the wires such as heater controls or wiper motors.
6. Route all power and signal cables as far as possible from other vehicle wiring harnesses. Loom when appropriate.
7. It is recommended that the equalizer be grounded directly to the chassis of the Source 1 head unit. The Source 1 head unit should be grounded at a chassis point (preferably bare or scraped sheet metal) other than the factory head unit ground wire or under dash brackets.
8. Use only the supplied machine screws to mount the equalizer or damage to the circuitry could occur.

CONTROL PANEL FEATURES

Adjustment Knobs

The PAR-650 five-band parametric equalizer features dual-function control knobs that extend when needed for adjustments and retract when not in use, allowing full adjustability with minimum control panel clutter. When the knobs are extended for adjustment they have an in and out position that allows each knob to control multiple processor settings.

- **Extend and Retract Knobs** - To extend and retract the adjustment knobs, press and release them into the control panel; they will extend or

retract with each press.

- **IN and OUT Position** - A knob is set to its in position when it is initially extended. To set a knob to its out position pull gently on the knob until a plainly-felt notched position is reached.

NOTE: *DO NOT use excessive force when using the adjustment knobs or damage to their release mechanism can result.*

1. Master Volume/Fader Control Knob

- **IN/Volume** - When in, this knob controls the overall volume of the system. It affects all line-level outputs to the amplifiers.
- **OUT/FADER** - When out, this knob controls the front to rear balance of the high-pass output jacks.

2. Input Source LED - The color of the LED indicates which input source is currently active.

- **GREEN** - Indicates Source 1 is active.
- **RED** - Indicates Source 2 is active.
- **ORANGE** - Indicates the control panel AUX is active.

3. Input Source Switch - This is a momentary push-button switch that will cycle through the three input sources by activating a new input source each time it is pressed.

NOTE: *The EQ defaults to SRC 1 when the unit is switched on.*



4. Subwoofer Volume Control

- **IN/SUB VOLUME** - When in, this knob controls the dedicated subwoofer output volume.
- **OUT/SUB VOLUME** - When out, this knob controls the low-pass

crossover frequency for the dedicated subwoofer output between 30–400 Hz at 12dB/octave.

5. High-Pass Output Frequency Control

- **IN/FRONT OUT FREQUENCY** - When in, this knob controls the high-pass crossover point for the front outputs between 30 Hz and 400 hz at 12dB/octave.
- **OUT/REAR OUT FREQUENCY** - When out, this knob controls the high-pass crossover point for the rear outputs between 30 Hz and 400 hz at 12dB/octave.

NOTE: *If rear panel switch #7 is in the full range position this knob has no function.*

6. Frequency Controls

- **IN/FREQUENCY GAIN CONTROL** - When in, these knobs control the gains for their respective frequencies. The center position is flat with a maximum +18db and -18dB adjustment capability.
- **OUT/PARAMETER CONTROL** - When out, these knobs control the center frequency of their respective filter band. The center frequency ranges are described in the chart below.

Control Knob	Filter Parameter
Subwoofer	30 to 70 Hz
Midbass	125 to 250 Hz
Low Midrange	400 to 800 Hz
High Midrange	1 to 5 kHz
High Frequencies	8 to 20 kHz

- 7. Aux In** - This is a 3.5 mm stereo input jack for use as an auxiliary input for portable music players, laptops, camcorders, or video games.

CONTROL PANEL

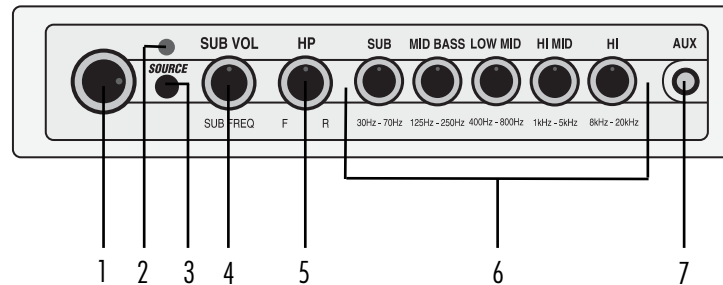

REAR PANEL FEATURES

Power Connector

- 1. Remote Turn On Output** - This output is intended to be the remote turn on for the system amplifiers and has a built-in delay. Two to three seconds after the PAR-650 receives a (+)12V turn on signal it will send a (+)12V turn on signal to the amplifiers. This feature is designed to eliminate system turn-on pops that can occur when several components turn on at the same time.
- 2. (+)12V Constant Power** - This is the main power input for the PAR 650 and must be connected to a (+)12V constant power supply. DO NOT connect this to a switched 12V source or the system may pop when the key is turned off.
- 3. Remote Turn On Input** - This is the input for turning on the PAR 650 and system amplifiers. It should be connected to the (+)12V remote turn on output of the system head unit. The PAR 650 has a built in turn off delay to prevent turn-off pops. When the remote turn on signal from the head unit shuts off, the amplifiers will turn off immediately and the PAR 650 will stay on for five seconds before turning off. This feature is designed into the PAR 650 to eliminate system turn off pops that can occur when several components turn off at the same time. DO NOT connect this to a (+)12V constant power supply.
- 4. Ground** - Connect this terminal to a quality ground location, preferably the chassis of the head unit, which must itself be properly grounded to the vehicle chassis. It is not recommended that the factory radio ground be used for after market audio components.

5. **Power Fuse** - This fuse protects the PAR 650 on-board electrical components. Never replace this fuse with one of higher value or damage to the PAR 650 could occur and result in loss of your warranty.
6. **Illumination Switch** - This switch changes the front panel background lighting from BLUE to GREEN to match the vehicle dash or radio backlighting.
7. **High Pass Output Switch** - This switch controls whether the front and rear outputs are full range or crossed over as high pass outputs to the amplifiers. When set to high pass output the front and rear output crossovers are separately variable from 30 to 400Hz, by using the high pass frequency control knob (#5) on the front panel.
8. **Front Amplifier Output** - These are output jacks for sending the audio signal to the front amplifier.
9. **Rear Amplifier Output** - These are output jacks for sending the audio signal to the rear amplifier
10. **Subwoofer Amplifier Output** - These are output jacks for sending the audio signal to the subwoofer amplifier.
11. **Source 1 Input** - These is the input for the main source unit.
12. **Source 2 Input** - These is the input for the secondary source unit.

REAR PANEL

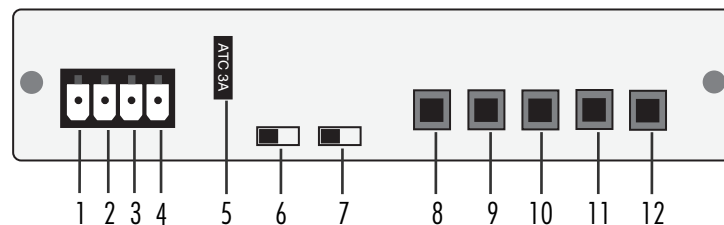

INITIAL SETTINGS

1. Make sure the main source unit is connected to the Source 1 inputs, then adjust the main source units volume to just below maximum.
2. Adjust the Source 1 input gains (top of unit) to the minimum setting and the PAR-650 master volume control to the maximum setting.

NOTE: *If connecting more than one input source to the PAR-650, use the Source 1 gain controls to match the input level of both sources.*

3. Set the filter gains to the flat (center) setting.
4. Complete all signal and power connections to the PAR-650.
5. Turn the system on and increase the gain on the Source 1 inputs until audible distortion can be heard. The system should be very loud at this time.
6. Reduce the PAR-650 master volume level and test for well-balanced and linear volume adjustment when using the Source 1 volume control.
7. When connecting a second source unit to the Source 2 input, the source one input gains (top of unit) may need further adjusting to achieve a close signal level match.

CROSSOVER AND FILTER ADJUSTMENTS

The crossover and filter gain adjustments can be performed two different ways, by using a piece of audio test equipment called an RTA (Real Time Analyzer) or by listening to a familiar piece of music. The RTA is most commonly used to achieve the flattest possible system response in preparation for a sound-off competition. Although an RTA may help in setting a flat system response, it does not allow for your personal listening preferences. When setting the EQ filter and gain controls using a familiar piece of music, adjustments can be made according the way you like the music to sound in relation to the vehicles acoustics and the type of drivers in the system.

1. Set all filter gain controls to their flat setting by adjusting all the filter knobs to the center or 0 setting when they are extended and set to their in position.
2. Set all frequency controls to their flat setting by adjusting all the filter knobs knobs to the flat or 0 setting when they are extended and set to their out position.
3. If using the dedicated subwoofer output, set its gain and frequency control to the center position.

NOTE: *When interfacing PPI class of amplifiers with non-defeatable low-pass crossovers adjust the amplifiers crossover point to its highest frequency setting.*

4. Turn on the head unit and play a familiar piece of music as reference material.

5. If the front and rear outputs have been set to high pass by setting the switch on the rear panel to the high pass setting, adjust the front crossover to the lowest possible setting with a minimum of distortion. Repeat for the rear speakers.
6. At this time adjust the subwoofer frequency and volume to match the crossover settings for the satellite speakers. When set properly the bass should not be localized and voices should not be heard through the subwoofers.
7. Adjusting the frequency control knobs out direction from center will change the center frequency and bandwidth parameter for that particular filter. The higher the frequency (clockwise) for a filter the wider bandwidth, the lower the frequency (counter-clockwise) the narrower bandwidth.
8. Once the center frequencies and bandwidth have been adjusted controls have been set, use the filter gains (filter knob's in position) to fine tune the system for differing tastes in music or material.

SYSTEM DIAGRAM

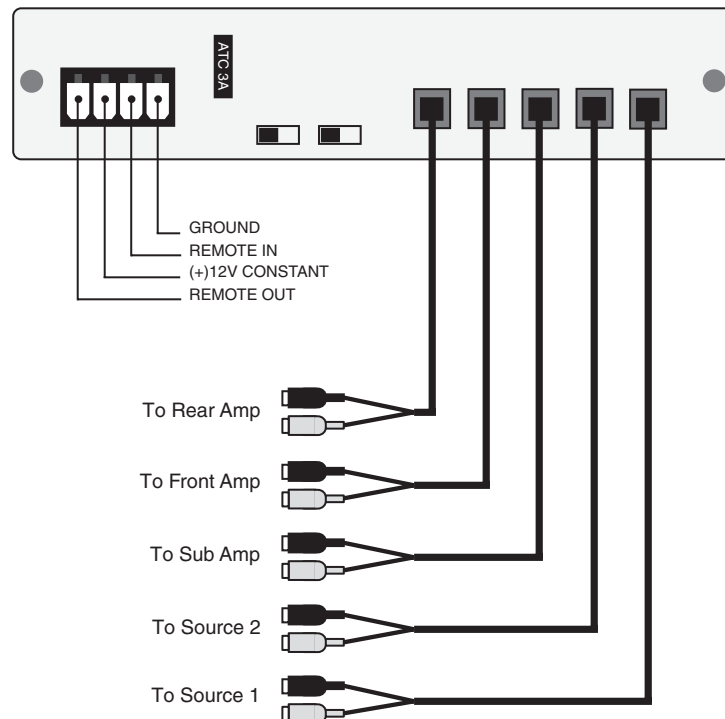

SPECIFICATIONS

PRECISION POWER PAR-650

Filter Parameters	Sub 30-70Hz Mid-bass 125-250Hz Low-mid 400-800Hz Hi-mid 1.5-5kHz Hi 8-20kHz
Boost/Cut	18dB/octave maximum
Filter Bandwidth	Varies with center frequency
Crossover/Range	LP/HP, 12dB/octave, variable 30-400Hz
Signal-to-Noise Ratio	100dB @ 1 volt input
Frequency Response	20Hz-30kHz, +/- 0.5dB
Maximum Output Voltage	6V RMS front/rear outputs 10V RMS subwoofer output
Output Impedance	500 ohm
Gain (all filters set flat)	1V in = 2V (front/rear) 6V (sub)
Total Harmonic Distortion	< 0.006%
Stereo Separation	>75dB @ 1kHz
Input Sensitivity	50mv - 4.0V RMS (fixed inputs) 50mv - 10V RMS (variable input)
Input Impedance	21K ohms
Operating voltage/fuse	11-15V negative ground/3A ATC
Remote Out	500mA @ 11.5V
Size (H x W x D)	1"x 7"x 4-3/4"

Warranty

LIMITED TWO YEAR CONSUMER WARRANTY:

Directed Electronics, Inc. promises to the original purchaser, to replace this product should it prove to be defective in workmanship or material under normal use, for a period of two years from the date of purchase from the dealer as indicated by the date code marking of the product PROVIDED the product was installed by an authorized Directed dealer. During this two-year period, there will be no charge for this replacement PROVIDED the unit is returned to Directed, shipping pre-paid. If the unit is installed by anyone other than an authorized Directed dealer, the warranty period will be one year from the date of purchase by the dealer as indicated by the date code marking of the product. This warranty is non-transferable and does not apply to any unit that has been modified or used in a manner contrary to its intended purpose, and does not cover damage to the unit caused by installation or removal of the unit. During this one-year period, there will be no charge for this replacement PROVIDED the unit is returned to Directed, shipping pre-paid. This warranty is void if the product has been damaged by accident or unreasonable use, neglect, improper service or other causes not arising out of defects in materials or construction. Units which are found to be damaged by abuse resulting in thermally damaged voice coils are not covered by this warranty but may be replaced at the absolute/sole discretion of Directed. **ALL WARRANTIES INCLUDING BUT NOT LIMITED TO EXPRESS WARRANTY, IMPLIED WARRANTY, WARRANTY OF MERCHANTABILITY, FITNESS FOR PARTICULAR PURPOSE, AND WARRANTY OF NON-INFRINGEMENT OF INTELLECTUAL PROPERTY ARE EXPRESSLY EXCLUDED TO THE MAXIMUM EXTENT ALLOWED BY LAW, AND DIRECTED NEITHER ASSUMES NOR AUTHORIZES ANY PERSON TO ASSUME FOR IT ANY LIABILITY IN CONNECTION WITH THE SALE OF THE PRODUCT. DIRECTED HAS ABSOLUTELY NO LIABILITY FOR ANY AND ALL ACTS OF THIRD PARTIES INCLUDING ITS AUTHORIZED DEALERS OR INSTALLERS.** Unit must be returned to Directed, postage pre-paid, with bill of sale or other dated proof of purchase bearing the following information: consumer's name, telephone number, and address, authorized dealer's name and address, and product description. Note: This warranty does not cover labor costs for the removal and reinstallation of the unit. **IN ORDER FOR THIS WARRANTY TO BE VALID, YOUR UNIT MUST BE SHIPPED WITH PROOF OF INSTALLATION BY AN AUTHORIZED DIRECTED DEALER. ALL UNITS RECEIVED BY DIRECTED FOR WARRANTY REPAIR WITHOUT PROOF OF DIRECTED DEALER INSTALLATION WILL BE COVERED BY THE LIMITED 1 YEAR PARTS AND LABOR WARRANTY.** Note: This warranty does not cover labor costs for the removal and reinstallation of the unit. **BY PURCHASING THIS PRODUCT, THE CONSUMER AGREES AND CONSENTS THAT ALL DISPUTES BETWEEN THE CONSUMER AND DIRECTED SHALL BE RESOLVED IN ACCORDANCE WITH CALIFORNIA LAWS IN SAN DIEGO COUNTY, CALIFORNIA.**

