



## **CONTENTS**

(click on a topic to view)

**Congratulations**

**Features and Specifications**

**Mounting**

**Mounting**

**Wiring**

**Wiring**

**Functions**

**Functions**

**System Tuning**

**Frequency Distribution**

**System Diagram**

**Troubleshooting**

**Block Diagram**

**Warranty**

## Congratulations and thank you.....

for choosing *PrecisionPower* audio equipment. At *PrecisionPower* we proudly design, engineer and manufacture audio products at our facility in Phoenix, Arizona. Our award winning engineering team utilizes innovative technology to consistently deliver Absolutely State of the Art™ performance, sound quality, reliability, and value. This *PrecisionPower* product reflects our commitment to offer you unparalleled versatility and quality for years of dependable service and listening enjoyment.

### Service



Do not attempt to service *PrecisionPower* products yourself. Performing exploratory surgery on your audio equipment yourself will void the warranty. Many parts of your *PrecisionPower* gear are custom built to our specifications. Our factory parts are not made available to anyone else nor are they for sale. Our goal is to make sure that your *PrecisionPower* product will always sound as good as the day it was purchased. Contact your authorized *PrecisionPower* dealer about obtaining any warranty service through *PrecisionPower*.(See Warranty inside back cover)

### FOR YOUR RECORDS:

M o d e l \_\_\_\_\_

Serial Number \_\_\_\_\_

Purchase Date \_\_\_\_\_

### Caution!



The extended use of a high powered audio system may result in hearing loss or damage. While *PrecisionPower* systems are capable of "Concert Level" volumes with incredible accuracy, they are also designed for you to enjoy at more reasonable levels all of the sonic subtleties created by musicians. Please observe all local sound ordinances.

**BACK TO CONTENTS**

# FEATURES / SPECIFICATIONS

4 Band Graphic Equalizer  
Preamp Line Driver  
Ultra-Wide Bandwidth Circuitry  
Adjustable Input Sensitivity  
Center-Detented Boost/Cut Controls  
12dB Boost/Cut for Each Band  
Gold-plated RCA Input and Output Connectors  
PWM (Pulse Width Modulated) Power Supply  
Designed and Handcrafted in the U.S.A.

## Specifications



*Signal-to-Noise Ratio* 102dB  
*Total Harmonic Distortion (1 kHz, 1 VRMS)* 0.0074%  
*Boost/Cut Range* ±12dB

*Equalizer Center Frequencies:*

<u>Band</u>	<u>Frequency</u>
<i>Sub</i>	40 Hz
<i>Low</i>	100 Hz
<i>Mid</i>	2 kHz
<i>Treble</i>	6.5 - 26 kHz (Shelf EQ)

*Maximum Input Voltage (Flat)* 3.5 VRMS  
*Maximum Output (10 kΩ Load)* 8.5 VRMS  
*Frequency Response* 10 Hz to 100 kHz  
*Supply Voltage* 11 - 15 VDC  
*Dimensions* 3.20" L  
6.75" W  
0.95" H

# MOUNTING

## Mounting



To prevent damage to the **PEQ-114** while driving, mount it in a secure place. Choosing the appropriate location will depend upon your vehicle and the complexity of your system design. Typical mounting locations for your new **PEQ-114** would be in the dash or center console. Never mount the component in a location that would subject it to immersion or exposure to water.



Once a location has been chosen, securely mount the **PEQ-114** using the two supplied brackets. There are two different sets of brackets included with your **PEQ-114**. One set is used to flush mount the equalizer, as shown above. The other set is used for surface mount, as shown on the next page. The brackets are connected to the equalizer/preamp by two 6-32 x 1/4" socket head cap screws. We have made the brackets adjustable to compensate for the uniqueness of each vehicle. Be Careful! Inspect the area underneath to be sure you are not drilling into wires, etc. that could be damaged by the drill bit or screws.

# MOUNTING

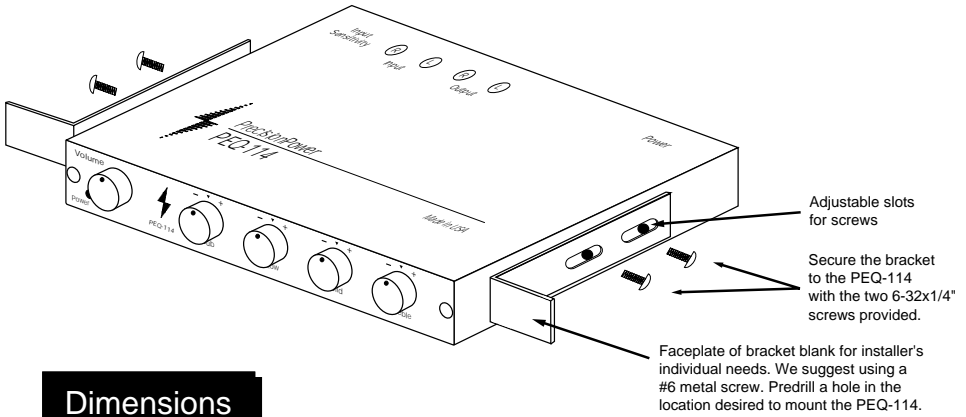

## Dimensions

6.75"W  
3.20" L  
0.95"H

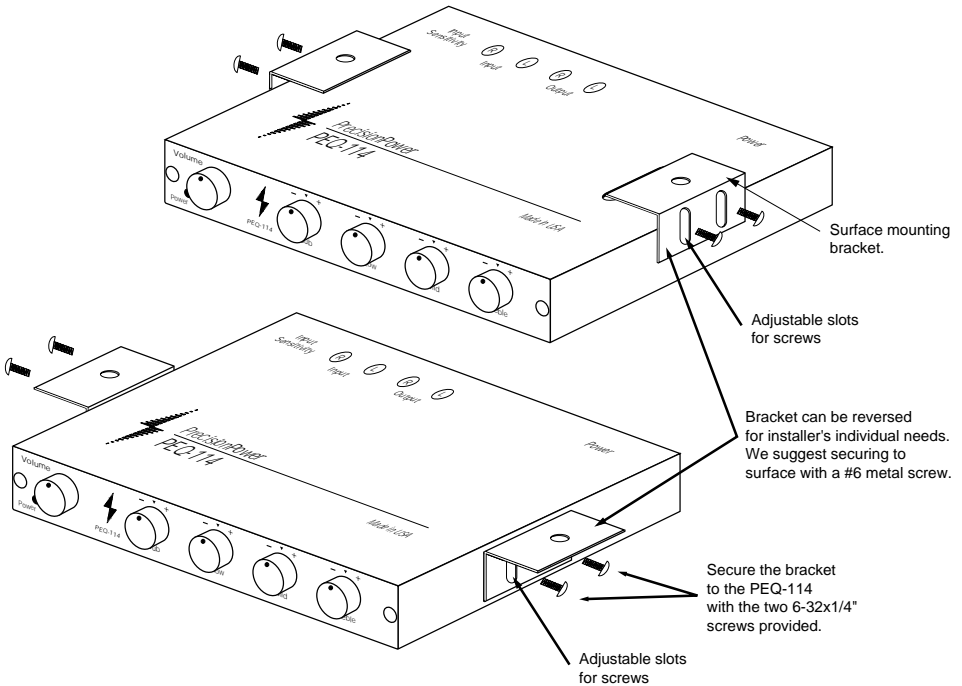

# WIRING

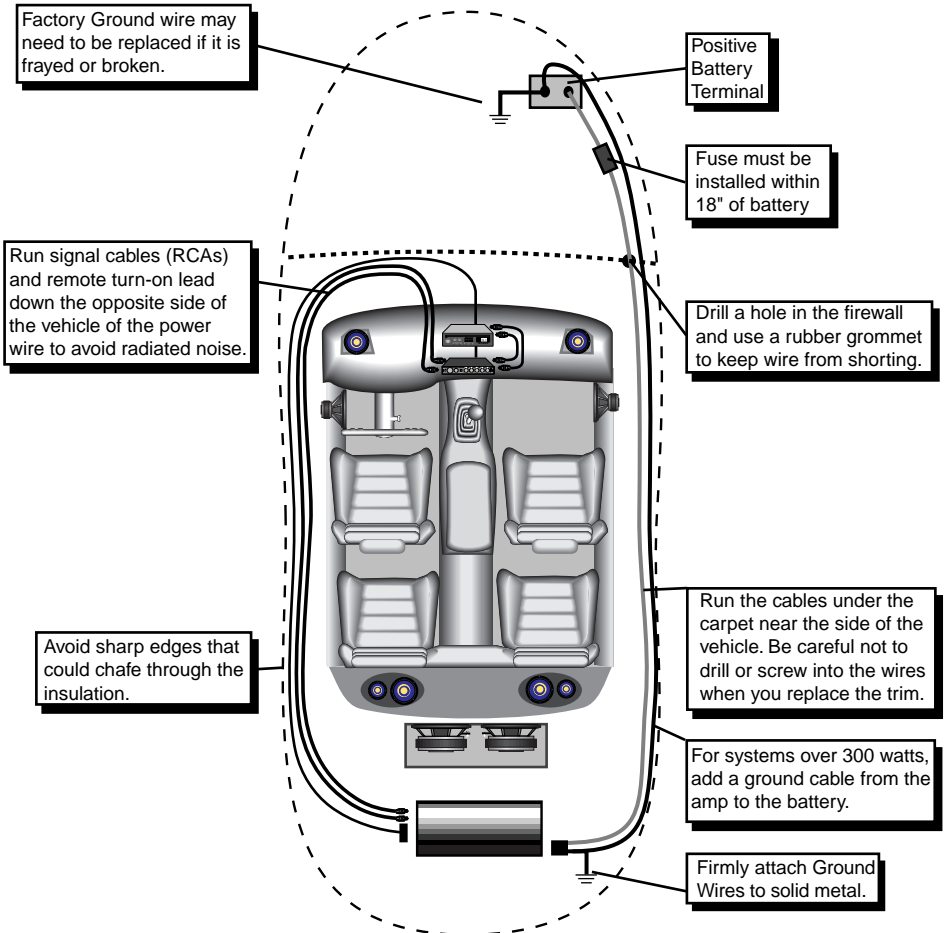

## NOTE



Before beginning, disconnect the negative (-) terminal of the battery prior to working on the positive (+) terminal to prevent a short to ground. This is important, unless you want to spend the rest of your life with a nickname like "*Sparky*," or "*Smokey*." Reconnect the negative terminal only after all connections have been made.

## WIRING

The next step is to connect the Power, Ground, and Remote wires to your **PEQ-114**. The power wire should run from the mounting location through the vehicle to the battery or power distribution block. Avoid sharp corners, creases, and sharp body parts. When passing through any metal wall (i.e. firewall etc.), a grommet must be used to prevent the wire from chaffing and shorting to ground.

The ground wire should be of the same gauge as the power wire. As a rule of thumb, use as short a length of wire as possible.

Find a location near the equalizer that is metal (the floor is ideal) and clean an area about the size of a quarter to bare metal. Drill a pilot hole in the middle of this area. Be Careful! Inspect the area underneath to be sure you are not drilling into wires, brake or fuel lines, etc. Terminate the wire with a ring connector and attach it to the bare metal using a #8 sheet metal screw and washer (not supplied). We suggest crimping and/or soldering this connection. After the connection is complete, coat the area with silicone or some similar material to prevent rust from developing.

Finally, the remote wire needs to run to the power antenna (or amplifier remote) lead of the head unit. This wire supplies a 12 volt signal to the **PEQ-114** when the main system is activated.

Once you have routed the power, ground, and remote wires through the vehicle, it is time to connect the wires to the **PEQ-114**. Be sure that you have not reconnected the ground cable to the negative post of the battery.

Cut off excess wire and, using wire strippers, strip the power, ground and remote cables about 1/8 inch. Locate the power, ground, and remote **Powerlock** connector (supplied). On the top of the connector are three slotted screws. With a small flat-bladed screwdriver, loosen the screws before attempting to insert the cables. After you have inserted the stripped end of each cable into the connector, secure it by tightening the associated screw. Check that each connection is tight. If the wires are secure, the connector may be plugged into the **PEQ-114**.

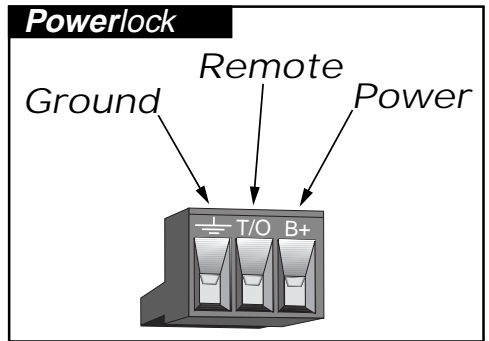

# FUNCTIONS

## 1. Volume

Set the source unit at 3/4 full volume, and use this control as the Master volume control.

## 2. Sub

Subwoofer (40 Hz) Boost/Cut control.

## 3. Low

Low (100 Hz) Boost/Cut control.

## 4. Mid

Midrange (2 kHz) Boost/Cut control.

## 5. Treble

Treble (6.5 kHz - 26 kHz, Shelving) Boost/Cut control.

## 6. Power LED

Red light indicates power on.

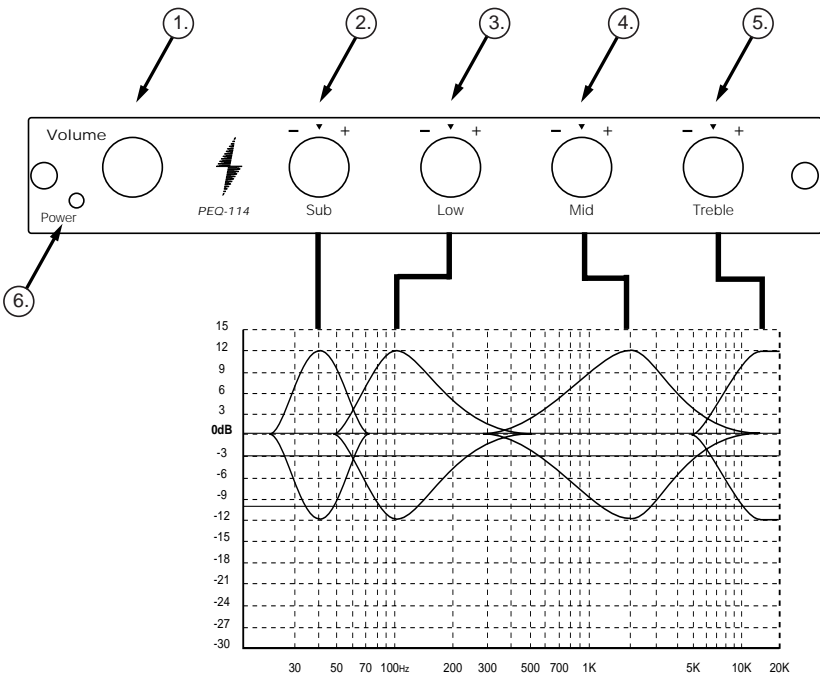



# FUNCTIONS

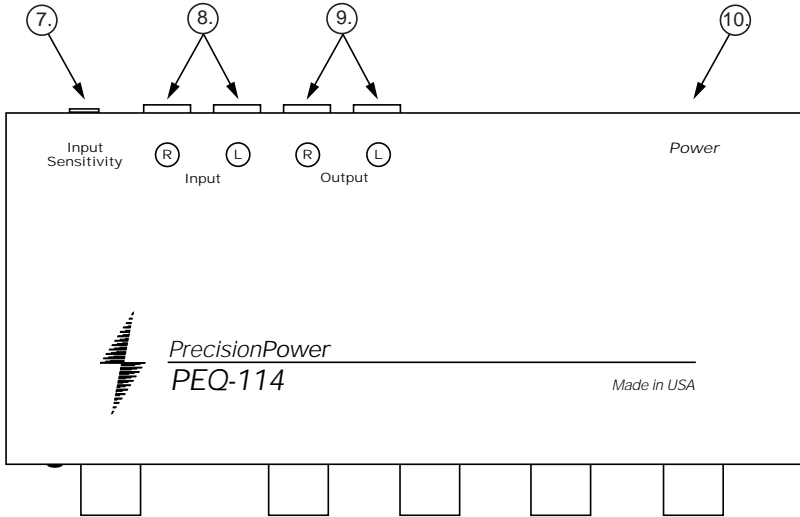

## 7. Input Sensitivity

Sets input gain to match the output level from the source unit (See Page 8).

## 8. Input

Gold plated RCA inputs. Plug in the RCA cables from the source unit here.

## 9. Output

Gold plated RCA outputs. Plug in the RCA cables to your amplifier here.

## 10. Power

After connecting the Power, Ground and Remote wires, plug in the PowerLock connector here.

# SYSTEM TUNING

## System Gain Adjustment



In order to achieve maximum signal-to-noise performance from a high quality auto stereo system, it is desirable to use high signal levels wherever possible in the interconnect cables. High signal levels will reduce the effect of induced noise. The peak level of an audio signal is usually determined by the clipping level of electronic components. The following procedure should be used as a guide before the system installation is completed.

Adjustment of source unit output and **PEQ-114** input:

1. Turn **PEQ-114** volume control fully counterclockwise.
2. Turn source unit volume 1/2 to 3/4 of maximum.
3. Adjust the **PEQ-114** input gain fully counterclockwise.
4. Play a CD or cassette. A loud music selection is desired.
5. Turn **PEQ-114** volume control clockwise to a comfortable listening level, about 1/2.
6. Adjust the input gain control clockwise until the onset of audible distortion. Then adjust the control counterclockwise slightly. This setting will minimize system background noise and prevents overloading the **PEQ-114**.

## Adjusting Your Equalizer



The four bands (Sub, Low, Mid, and Treble) on your **PEQ-114** have been designed to adjust the frequencies that are most often out of balance in a car.

1. To achieve the tonal balance you desire, listen to some favorite music selections with the **PEQ-114** bands set “flat”, that is, with the knobs straight up. Listen for individual instruments that seem too loud (or too soft) and look up the instrument in the Frequency Distribution chart on the facing page to see which frequencies they represent.
2. Looking at the Diagram on page 6, find the boost/cut control that best matches the instrument you want to adjust.
3. Turn the control down (or up) until the instrument blends with the rest of the music.

# FREQUENCY DISTRIBUTION

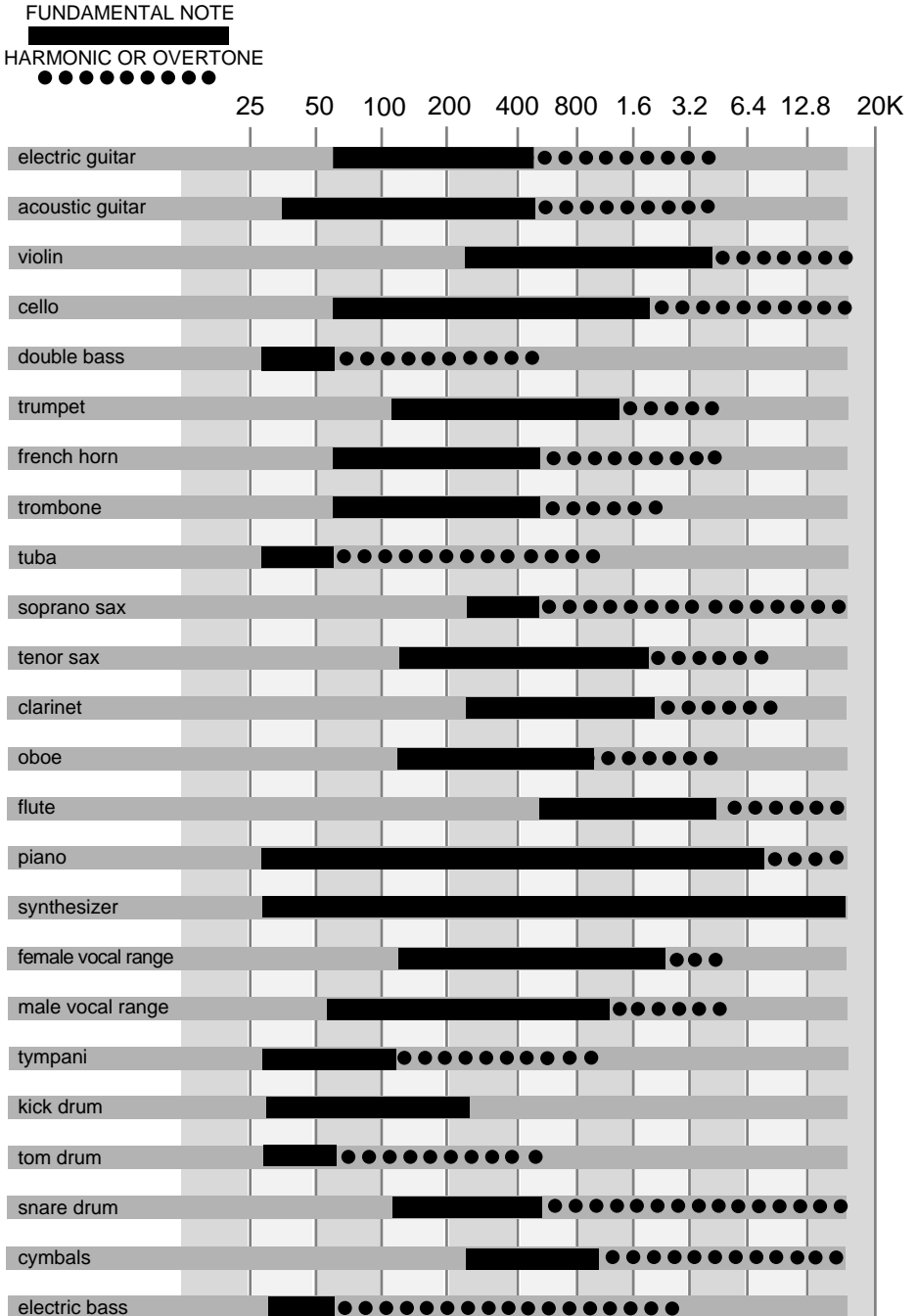

# SYSTEM DIAGRAM

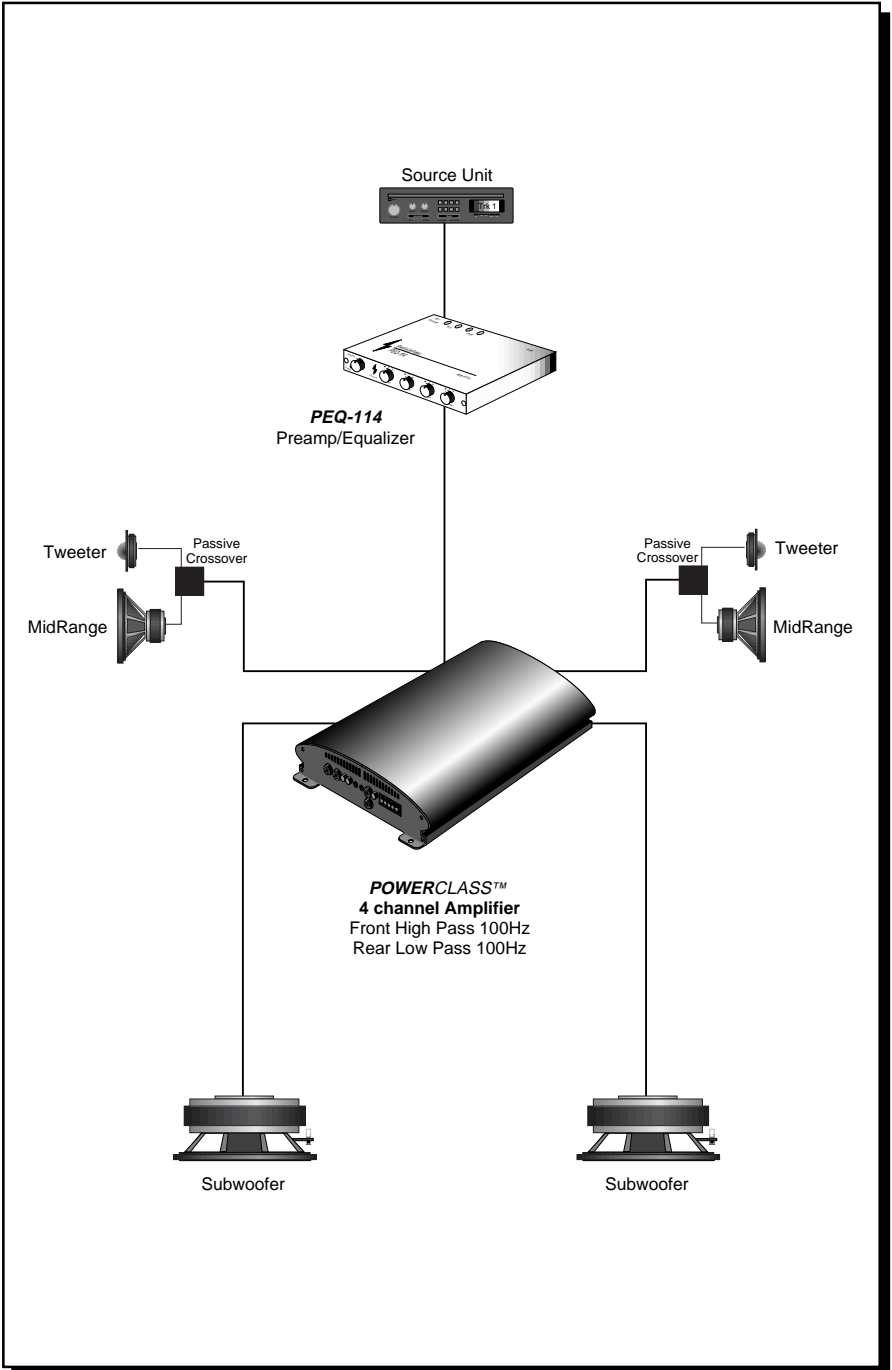

# TROUBLE SHOOTING

## NO SOUND

Is the LED lit?

**YES**

Check Input cables for signal by connecting them to the next component in line.

**NO**

Check Power and Remote turn-on wire for voltage. Make sure Ground wire is secure.



**ANY SOUND NOW?**

**YES**

Problem is in the Equalizer. See your local Authorized *PrecisionPower* Dealer or call 1-800-62**POWER**.

**NO**

Problem is elsewhere in the system. Check head unit and amplifiers.

## SOUND IN ONE CHANNEL ONLY

Check Balance control.

Reverse left and right RCA outputs.



**SOUND IS NOW IN**

**OPPOSITE CHANNEL**

Reverse RCA inputs.

**SAME CHANNEL**

Problem is in the amplifier, speakers or associated wiring of the silent channel.



**SOUND IS NOW IN**

**OPPOSITE CHANNEL**

Reverse RCAs at head unit.

**SAME CHANNEL**

Problem is in the Equalizer. See your local Authorized *PrecisionPower* Dealer or call 1-800-62**POWER**.



**SOUND IS NOW IN**

**OPPOSITE CHANNEL**

Problem is in the head unit.

**SAME CHANNEL**

Problem is in the RCA cables.

# BLOCK DIAGRAM

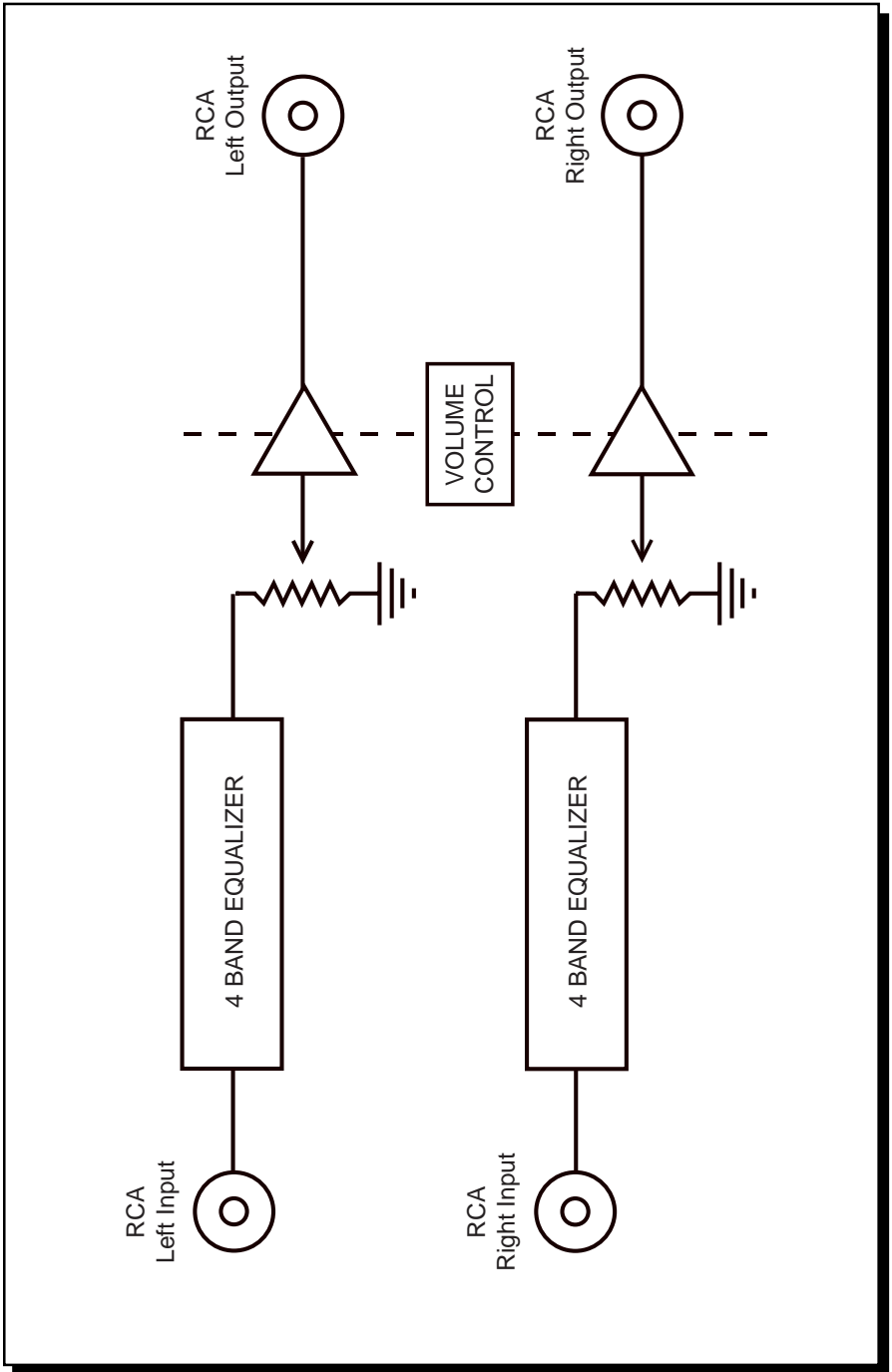

# WARRANTY

## Three-Year Limited U.S.A. Warranty

This warranty gives you specific legal rights, and you may also have other rights which vary from state to state. *PrecisionPower* warrants its products to be free from defects in materials and workmanship under normal use and service for a period of three (3) years from the date of original purchase when the unit is installed by an Authorized Dealer. Non-Authorized Dealer installed products carry a one (1) year parts and ninety (90) days labor limited warranty. The extent and conditions of Limited Warranty are as follows:

1. Authorized Dealer Installed Products: *PrecisionPower* will either repair or replace at no charge, to the original purchaser, any unit which *PrecisionPower's* examination discloses to be defective and under warranty, provided the defect occurs within three (3) years from the date of original purchase when the unit is installed by an Authorized Dealer and the product is returned immediately to *PrecisionPower*. This warranty is not transferable.

2. Non-Authorized Dealer Installed Products: *PrecisionPower* will either repair or replace at no charge, to the original purchaser, any unit which *PrecisionPower's* examination discloses to be defective and under warranty, provided the defect occurs within ninety (90) days from the date of purchase and the product is returned immediately to *PrecisionPower*. Warranty claims beyond ninety (90) days for Non-Authorized Dealer Installed Products will be for parts only and will extend for one (1) year from the date of purchase. This warranty is not transferable.

3. The date of purchase and proof of Authorized Dealer Installation of a PrecisionPower product must be established by an original sales receipt which must accompany the article being returned for warranty work.

4. This warranty shall NOT apply to any *PrecisionPower* product found to have the original factory serial number removed or defaced. All products received (by *PrecisionPower*) for in warranty or out of warranty repair, with their original serial numbers removed or defaced, will NOT be repaired and will be returned to sender, freight collect. Refer to original packaging for the serial number of your component speakers.

5. The provisions of this warranty shall not apply to any *PrecisionPower* product used for a purpose for which it is not designed, which has been repaired or altered in any way, or which has been connected, installed, or adjusted other than in accordance with the instructions furnished in *PrecisionPower's* owner's manual. Nor shall this warranty apply to any part which has been subject to misuse, neglect, or accident.

6. PrecisionPower does not authorize any other persons to assume any other liability in connection with its products. THIS WARRANTY IS THE ONLY EXPRESS WARRANTY MADE BY PRECISIONPOWER APPLICABLE TO ITS PRODUCTS. ANY IMPLIED WARRANTY OR MERCHANTABILITY OR FITNESS FOR A PARTICULAR PURPOSE APPLICABLE TO PRECISIONPOWER PRODUCTS IS LIMITED IN DURATION TO THE DURATION OF THIS LIMITED WARRANTY. PRECISIONPOWER SHALL NOT BE LIABLE FOR THE INCIDENTAL, CONSEQUENTIAL, OR COMMERCIAL DAMAGES RESULTING FROM THE BREACH OF THIS WRITTEN WARRANTY. Some states or provinces do not allow the exclusion or limitation of incidental or consequential damages or limitations on how long an implied warranty lasts; so the above limitations or exclusions may not apply to you.

7. Your product will be serviced on an in-warranty basis within the warranty period for the correction of warranted defects. If improper operation of your *PrecisionPower* product should occur, contact your Authorized Dealer for assistance with the return and factory repair of your *PrecisionPower* product. If an Authorized Dealer is not available, return the unit including your name, telephone number, return address, a copy of your sales receipt, and a description of the problem to:

**PrecisionPower, Inc.  
Service Department  
4829 S. 38th Street  
Phoenix, AZ 85040-2964**

TO RETURN PRECISIONPOWER PRODUCTS OUT OF WARRANTY: Return the unit, postage prepaid, in the original protective carton. Please include a description of the problem and, if desired, a request for an estimate of repair costs. Unless a request for an estimate is included, the unit will be repaired as necessary. Please contact *PrecisionPower* Customer Service at 1-800-62-POWER for questions concerning out of warranty repair charges. Repaired unit will be returned with an itemized statement, C.O.D.

**BACK TO CONTENTS**