



PrecisionPower

Absolutely State of the Art Mobile Audio™



Owner's Guide

A2000.1 A2000.5 A2000.4 A1000.1 A1300.4

THANK YOU AND CONGRATULATIONS

Thank you for your decision to purchase a ATOM Series mobile amplifier! Our Amplifiers are the result of extensive engineering, testing, and bullet proof construction. Their versatility enables compatibility with optional signal and audio processors. These high quality MOSFET amplifiers may be configured to allow maximum flexibility in designing different types of speaker systems.

DIGITAL CLASS D FULL RANGE AMPLIFIERS

The ATOM Series are high quality MOSFET amplifiers that are capable of running a system full range, or they may be selected only to power subwoofers. It is important that you closely follow the wiring instructions contained in this Owners Manual so that you get the most from your ATOM Series mobile amplifier.

CAUTION

Some of our amplifiers are capable of producing a sound pressure level that can cause permanent damage to your hearing system. High sound pressure levels combined with long time listening can give permanent damage to your hearing system. Choose a listening level that is comfortable for your ear. To establish a safe level: Start your volume control at a low setting. Slowly increase the volume until you can hear the music comfortably and clearly, without any distortion. Sudden sound shocks are dangerous.

Atom amplifiers adopt the optimum class D performance, reliability, and footprint of the original Atom and iOn platforms. At first glance, you'll notice several key improvements. Atom's signal inputs, power/ground, and speaker connections are all re-located to the leading edge of the chassis, for an easier, more appealing install. All pre-amp & crossover options are conveniently located on the back side. What you might not notice are additions to the circuit board, including increased power supply & output stage components, & monoblock bridging capability. Installation of Atom amplifiers is unique, using mounting pedestals at each corner. The pedestals elevate the heatsink, improving airflow around and under the chassis. Additionally, rubber grommets under and inside each pedestal electrically isolate the amplifier chassis from the vehicle chassis, reducing potential for ground loop noise. Available mini 4ch & monoblock Atoms are a mere 6"x6" square, while higher power 4ch and monoblock are 10" long, and the 5ch is 13".

- High Efficiency Class D Full Range & Monoblock Amplifiers
- Hybrid Aluminum Alloy Heatsink for Optimum Dissipation
- Chassis Electrical Isolation & Air Convection Mounting Pedestals
- 2-ohm Stereo & 4-ohm Bridged Class D Full Range 4 ch. & 5 ch.
- 2-ohm Minimum Impedance Monoblock (A1000.1 only)
- 1-ohm Minimum Impedance Monoblock (A2000.1 only)
- Monoblock Bridging Capability for Double Amplifier Application
- MOSFET Power Supply w/ Audiophile Grade IRTM Transistors
- Military Grade SMT PCB Maintains Dynamic Performance
- Direct Short, Thermal, & Overload Circuits Protect Amplifier
- Quick Disconnect Power and Speaker Harness (A1300.4 & A1000.1)
- 200mV-6V Low Level RCA or High Level Signal Input
- Quick Disconnect High Level & RCA Wire Harness Included
- Easy DIY Install Single Sided Terminals & Controls
- 4g Power Input Terminals & 12g Speaker Output Terminals
- Variable 12dB High Pass, Low Pass, & Subsonic Crossovers
- 12dB Bass Boost Increases Low Octave Harmonics
- Dash Mount Gain Control Module Included (monoblocks & 5 ch.)

Installation of ATOM Series mobile amplifiers requires detailed knowledge of electronics wiring and proper speaker impedance. We strongly recommend installation by an authorized dealer. This Owners Manual only provides general installation and operation instructions. If you have any reservations about your installation skills, please contact your local dealer for assistance.

PREPARING FOR INSTALLATION

NOTE: *The tools listed below may be required for basic installation.*

- An electric drill with bits.
- Philips head and standard screwdrivers.
- Wire strippers.
- Crimping tool.
- VOM (electronic volt ohm meter).
- Heat shrink tubing and gun.
- Soldering iron.

INSTALLATION PRECAUTIONS

NOTE: *Proceed only if you are qualified installer otherwise, let your dealer do it. Always wear protective eyewear when using tools.*

- Turn off all stereo and other electrical devices before you begin.
- Disconnect the negative(-) lead from your vehicles battery.
- Locate all fuel lines, brake lines, oil lines, and electrical cables when planning the install.
- Make sure there is at least 2-inches (5 cm) around the air vents on the amplifier.
- When connecting ground points, make sure all paint is carefully scrapped away from
 - *The auto body and contact is made with bare metal.
- Use a utility knife to trim away fabric from hole locations before drilling or cutting.
- When running power cables through sheet metal, be sure to use grommets to properly insulate the metal edges from the wire insulation.
- If possible, use tubing through grommets.

MOUNTING THE AMPLIFIER

To keep your ATOM Series amplifier running at top performance, choosing the proper location is of utmost importance. For this reason the amplifier should be mounted in a location which will allow air to circulate freely. A clearance of at least 2-inches (5 cm) to all sides of the amplifier is necessary not only for proper cooling, but also for gaining access to the inputs and other variable controls. Be sure that the power and signal cable connections can enter and leave the amplifier in a straight line to avoid the risk of kinked wires causing a malfunction.

MOUNTING LOCATION

Your ATOM Series amplifier comes with mounting feet that need to be attached to the amplifier prior to installation. Once the feet are in place, use the amplifier as a template and mark the four screw locations. Use caution to make sure there are no objects behind the installation surface that may become damaged during drilling. The amplifier should be protected from exposure to moisture and direct sunlight. The best places to mount your amplifier are: The floor of the trunk, under the driver's seat, or on the back of the rear seat. For alternate installation locations.

WARNING

We recommend you to do a careful planning before you start to install this equipment. Choose a location for the amplifier which will allow plenty of air to circulate . Do NOT mount the amplifier upside down under the hat rack. In the amplifier case there are double mounting holes to make the installation job easier. The screws supplied in the plastic bag are self drilling when used with an electric screwdriver. If the surface where you intend to mount the amplifier isn't big enough you can mount the amplifier on a separate fiber board or similar. This will also isolate the amplifier chassis from ground.

NOTE! Before you start drilling, make sure that there are no fuel or brake lines or wiring looms behind where you intend to drill.

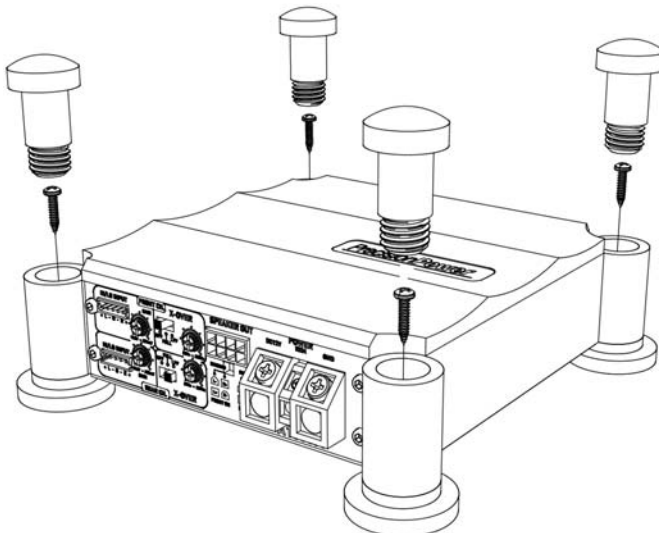

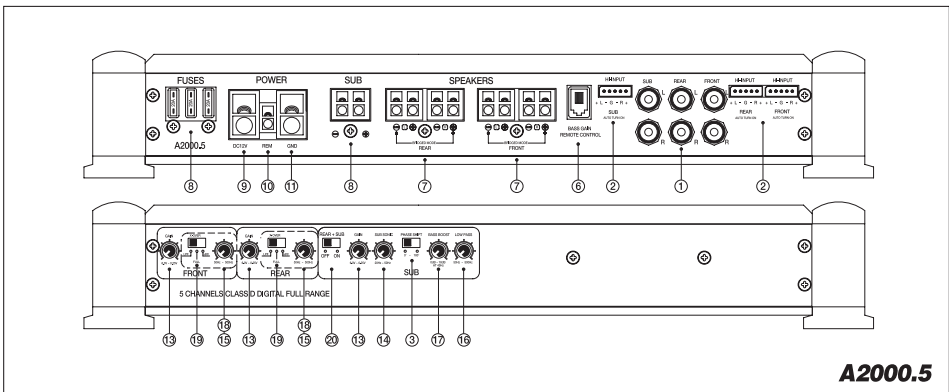
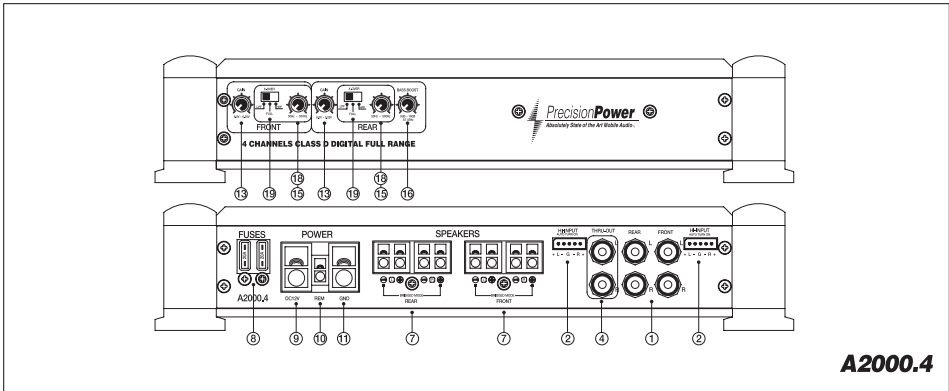
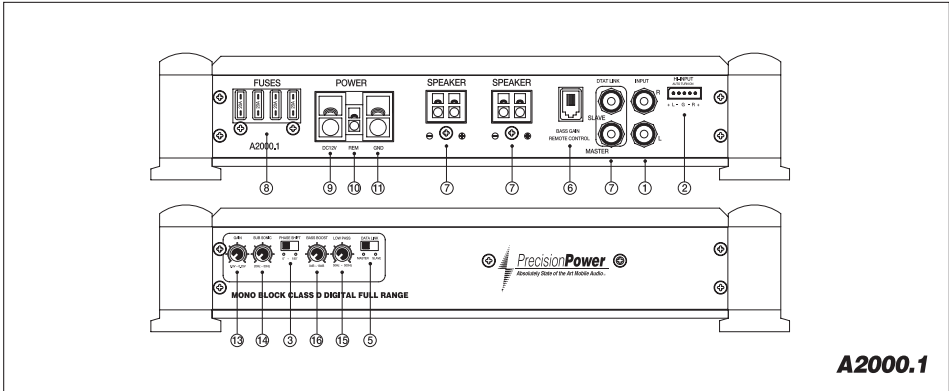

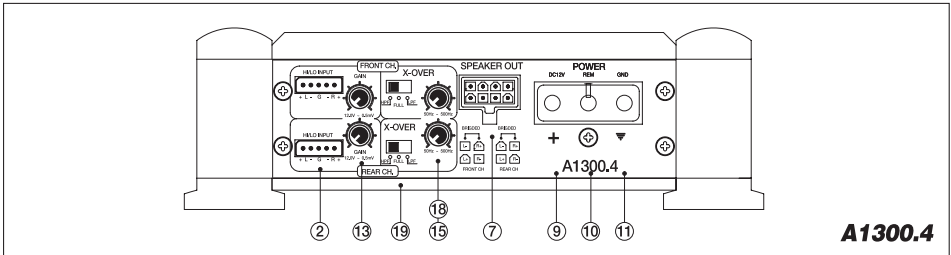
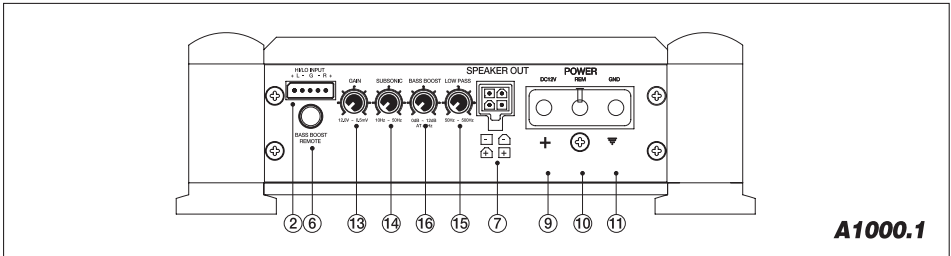

FUNCTIONS

1.LINE IN (RCA)

The RCA style input jacks are for use with source units that have RCA line level outputs. A source unit with a minimum of 250mV is required for proper operation. However, this input will accept levels up to 6Vrms.

2.High Level Input

If you are installing by using a high level . you do not need to connect to the remote. To hear a better sound quality, you must connect the high level ground wire to the head-unit ground.

3.Phase Shift

Phase Shift Switch (0 or 180 degrees): Allows you do change the phase of your subwoofer from 0 to 180 degrees to compensate for timing differences between drivers.

4.Thru-Out

The LINE OUT allows you to build multiple amplifiers systems without having to use splitter cords to distribute the signal. Now it is simply a matter of bringing one set of RCAS into the fist amplifier, then using the line out RCA jacks as the feed to the next amplifier.

5. Bridged Mode

Master Mode

For bridging into a single speaker load, To do this you must utilize the MASTER/SLAVE switch settings. For the MASTER amplifier, set the switch setting to MASTER. This will route the signal through RCA to the other (slave) amplifier. On the slave amplifier set this switch to the SLAVE position. Refer to Auxiliary Output Configuration section of this guide. Set the PHASE switch on the slave amp, move the phase switch from 0 to 180, exactly opposite of the master amp. Refer to the Phase Switches section of this guide.

Slave Mode

On the slave amplifier be sure to turn off all crossovers. For the speaker connections, connect the positive (+) speaker lead from the speaker to the positive (+) speaker terminal of the master amplifier. On the negative (-) speaker connection, take the negative (-) speaker terminal of the master amplifier and connect it directly to the negative (-) speaker terminal of the slave amplifier. The remaining positive (+) speaker terminal of the slave amplifier must be connected to the negative (-) speaker lead from the speaker. The impedance of the speaker must not exceed 2Ω . See diagram below.

NOTE: For best results, connect both negative speaker terminals on the master amp to both negative terminals on the slave amp using at least 12 AWG cable.

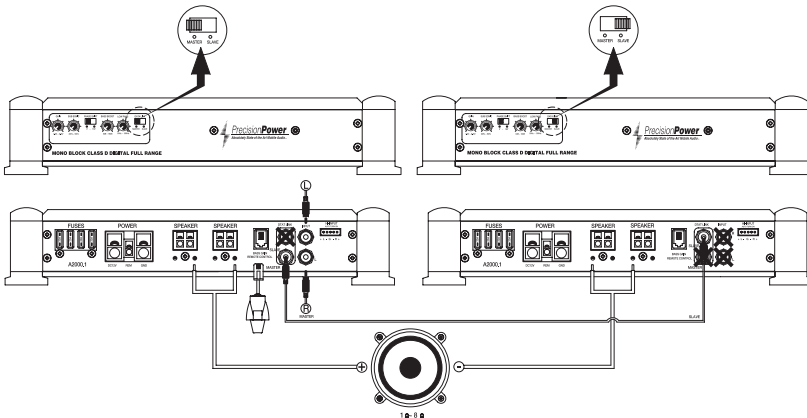

6. Remote Bass Boost Control

This control adjusts the Bass Boost gain for the amplifier's speaker output (0~ +12dB)
 * Packed product can be different from the photograph.

7. SPEAKER Terminals

As shown in the wiring diagrams, be sure to observe speaker polarity through the system and speaker impedance. This specially tooled terminal is designed to accommodate p to 10 gauge speaker wire.

8. FUSE

For convenience all ATOM Series amplifiers utilize common automotive ATC type fuses. For continued protection in the event that a fuse blows, replace the fuse only with the same value.

9. +BATT (Power Input Connection)

This terminal is the main power input for the amplifier and must be connected directly to the positive (+) terminal of the car battery.

10. Remote (Remote Input Connection)

All atom Series amplifiers can be turned on by applying 12 volts to this terminal. This can be found on the rear of the source unit in the form of an electric antenna output, or a remote output.

If this is not available you can wire to the ACC position on the key. An 18 gauge wire is sufficient to run the REMOTE.

11. GND (Ground Input Connection)

A good quality ground is required for your ATOM Series amplifier to operate at peak performance.

A short length of cable the same gauge as your power cable should be used to attached the ground terminal directly to the chassis of the vehicle.

12. Power Indicator

The GREEN when the power is on.
(PPI Logo Badge)

13. Gain adjustment control

The input level can be adjusted with this control. Turn it in the clockwise direction when the output level of the car audio unit seems low.

14. Sub Sonic Filter

Variable subsonic filter (20Hz ~50Hz)

The subsonic filter will roll off all of the unwanted frequencies below 20HZ ~50Hz. This will allow the amplifier to use that wasted power on the audible bandwidth.

15. Low pass Filter

ATOM amplifier has an internal variable low pass filter. It can be set from 50 p to 500Hz.

16. Bass boost level control

Turn this control to boost the frequencies around 45Hz to a maximum of 12dB.

17. Protection Indicator

When the PROTECTOR is activated, the indicator lights in red. When the PROTECTOR Is activated refer to the Troubleshooting Guide. (PPI Logo Badge).

18. High pass Filter

ATOM amplifier has an internal variable High pass filter. It can be set from 50 up to 500 Hz. It also has that can be set from 500 up to 5KHz.

19. High pass/ Full/Low pass selector switch

It is activated in each of the positions in top control.

20. Channel SUM selector switch

Choose OFF position for 4Ch. stereo input mode.

This allows the front & rear channels to receive signal from only the front & rear RCA inputs. Choose ON position. this allows for without 5channel(SUB) input.

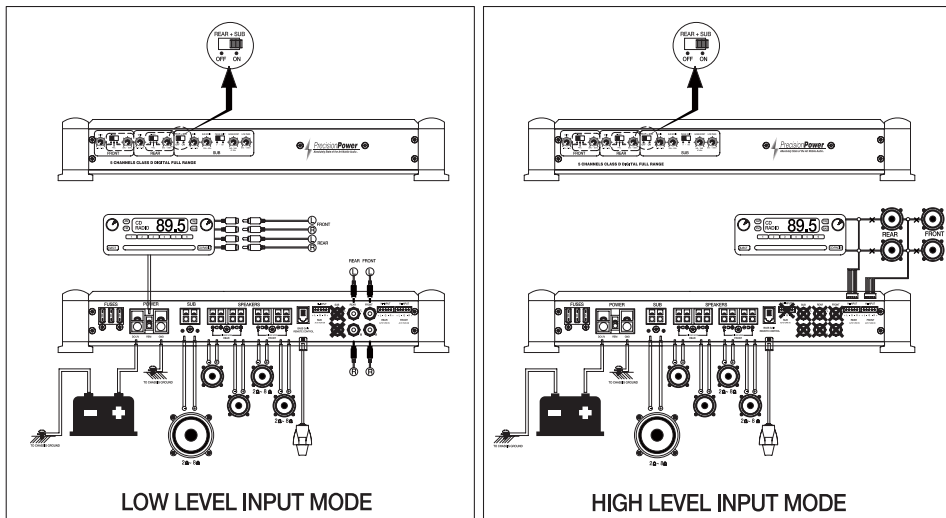

REMOTE SUBWOOFER LEVEL CONTROL

This input allows you to add remote that will allow you to control the subwoofer output of your ATOM amplifier from your dashboard. and to adapt the amplifier to all kind of signal sources with varying levels there are a level control provided on the amplifier next to the phone jacks. It should not be used as volume controls. Start with a "12' clock" setting of the level controls. If you set the head unit volume to 75% of maximum you should achieve a good sound without distortion. Find a point of the level setting where the distortion is just discernible. At this point slightly reduce the control.

HOW TO INSTALLATION

The dash control mounts with two screws, which attach to the underside of the dashboard. Slide under the dash and place the dash control in its mounting position, mark the two mounting holes, drill pilot holes, and secure with two screws.

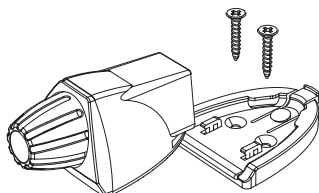

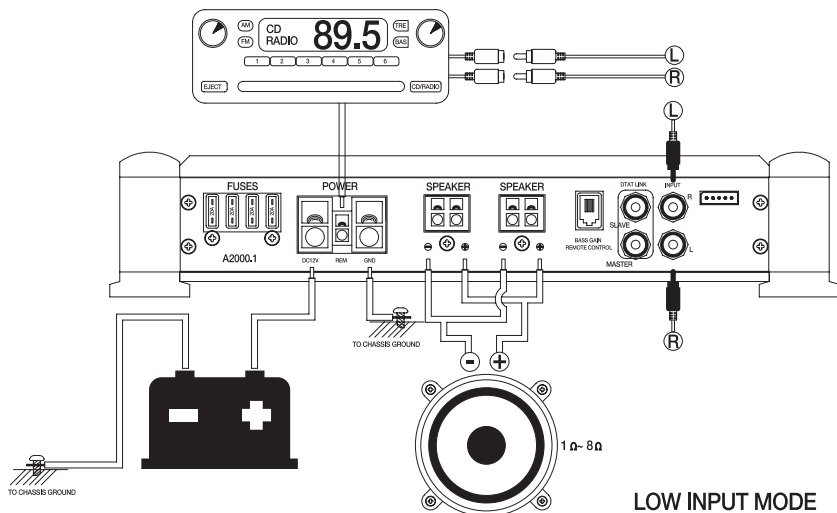

LOW INPUT MODE

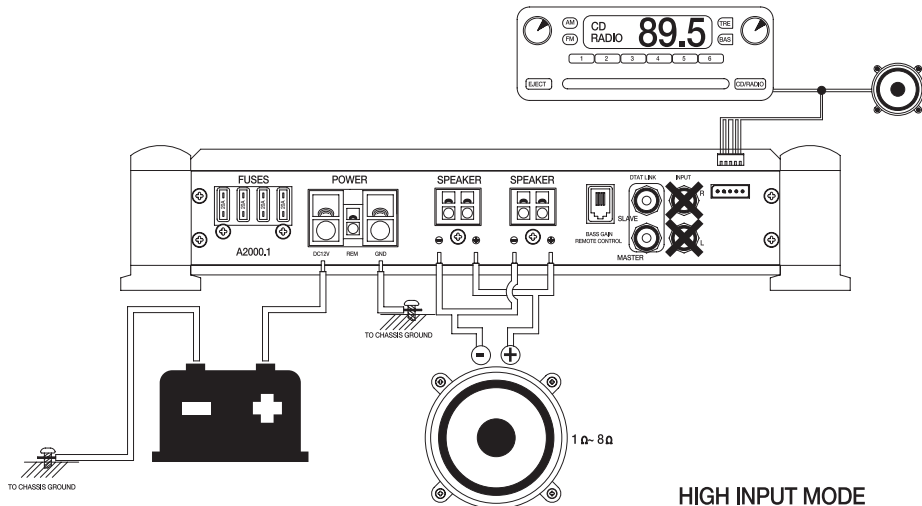

HIGH INPUT MODE

A2000.1		
400Wx1ch	40hm.	14.4V 100Hz RMS.
600Wx1ch	20hm.	14.4V 100Hz RMS.
1000Wx1ch	10hm.	14.4V 100Hz RMS.

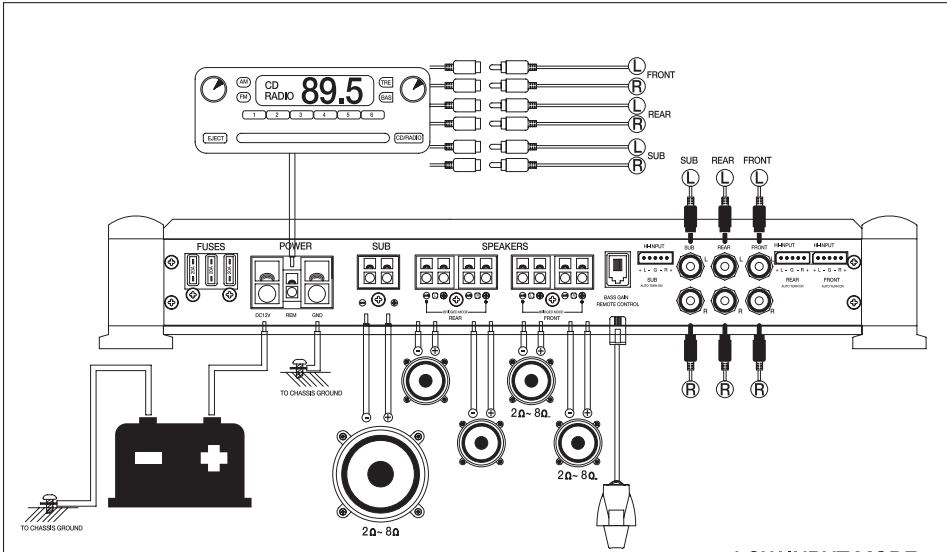

LOW INPUT MODE

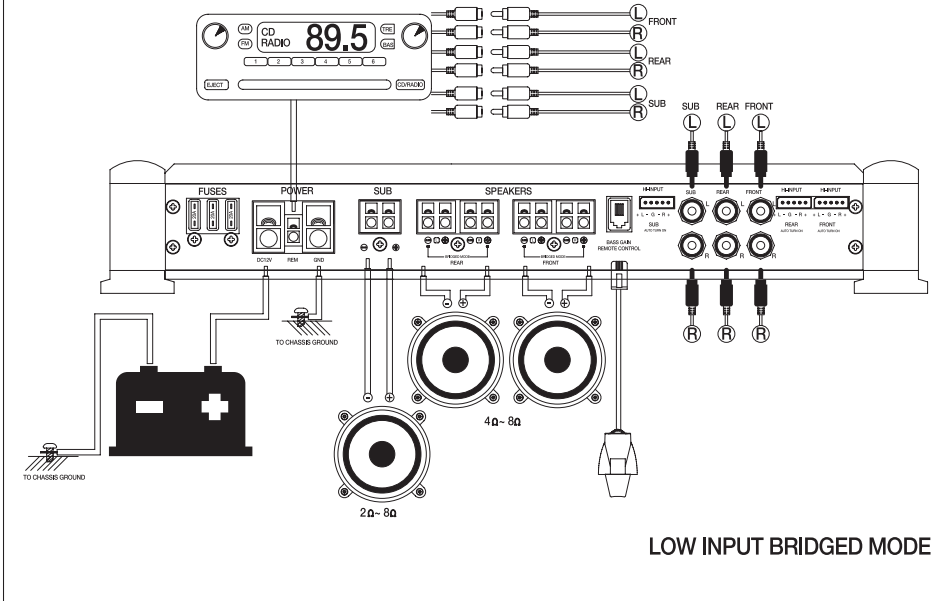

LOW INPUT BRIDGED MODE

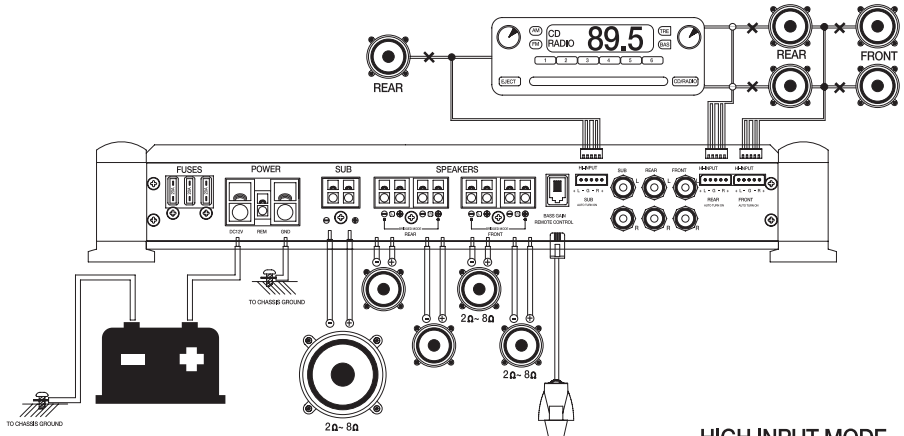

HIGH INPUT MODE

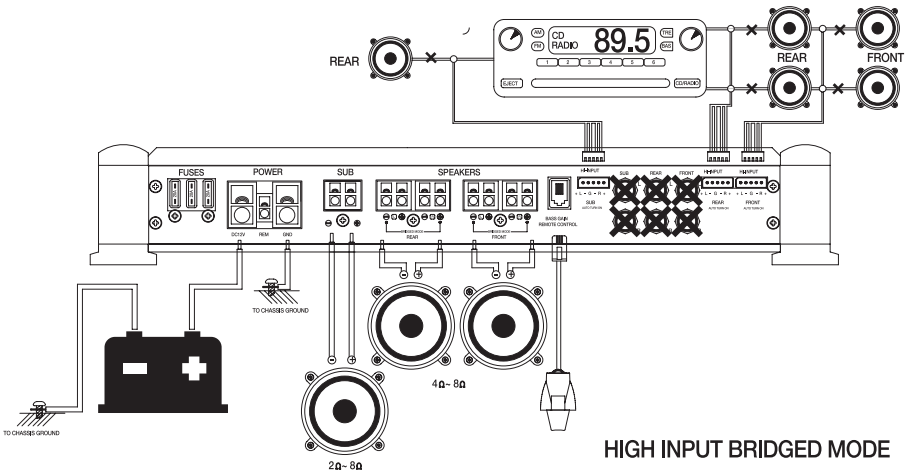

HIGH INPUT BRIDGED MODE

A2000.5		
80Wx4ch	4Ohm.	14.4V 1KHz RMS.
125Wx4ch	2Ohm.	14.4V 1KHz RMS.
250Wx2ch	4Ohm.	14.4V 1KHz RMS.
300Wx1ch.	4Ohm.	14.4V 100Hz RMS.
500Wx1ch.	2Ohm.	14.4V 100Hz RMS.

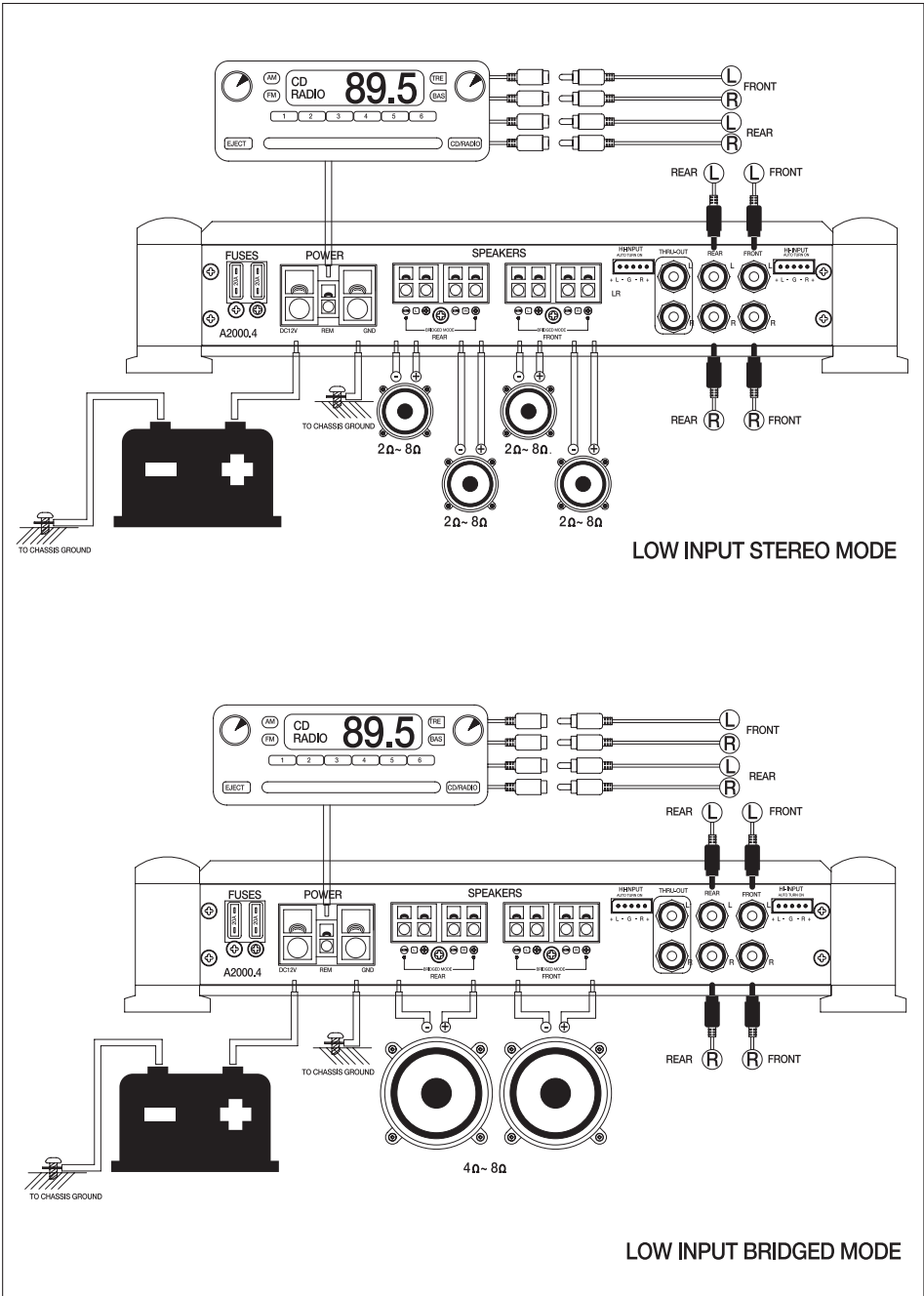

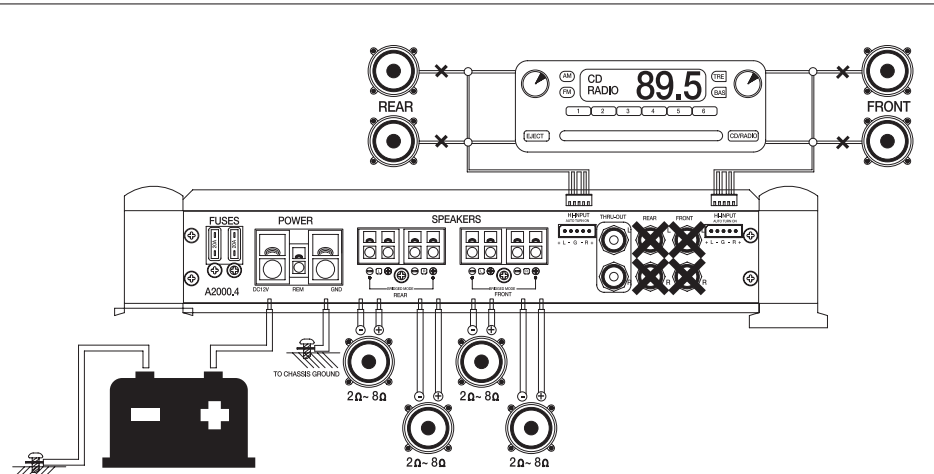

HIGH INPUT STEREO MODE

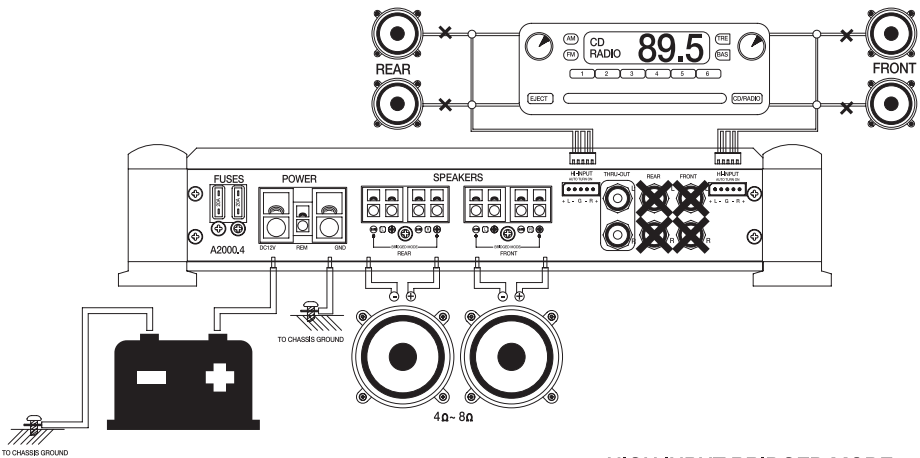

HIGH INPUT BRIDGED MODE

A2000.4		
180Wx4ch	40hm.	14.4V 1Khz RMS.
300Wx4ch	20hm.	14.4V 1Khz RMS.
500Wx2ch	40hm.	14.4V 1Khz RMS.

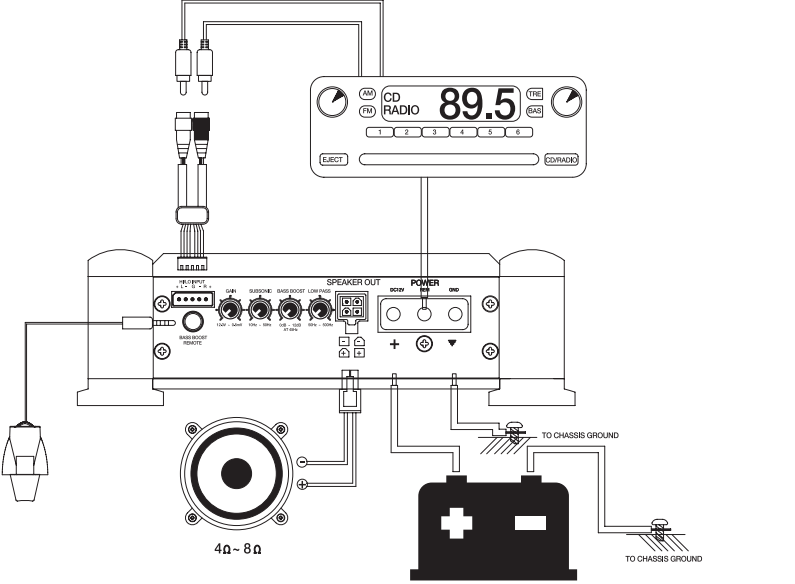

LOW INPUT MODE

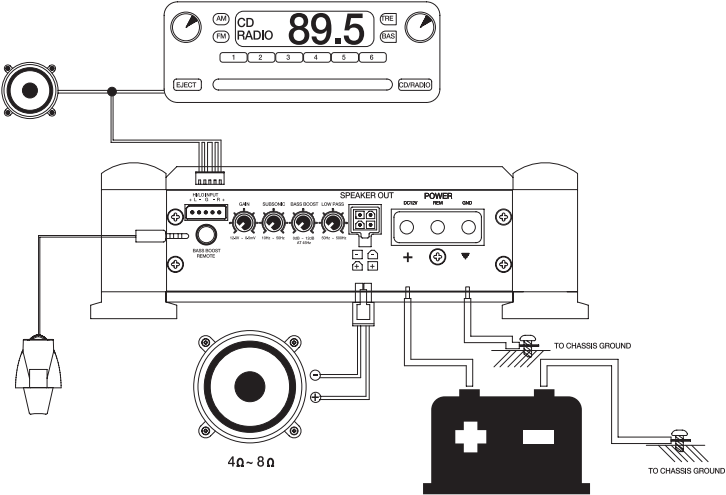

HIGH INPUT MODE

A1000.1		
200Wx1ch.	40hm.	14.4V 100Hz RMS.
350Wx1ch.	20hm.	14.4V 100Hz RMS.
500Wx1ch.	10hm.	14.4V 100Hz RMS.

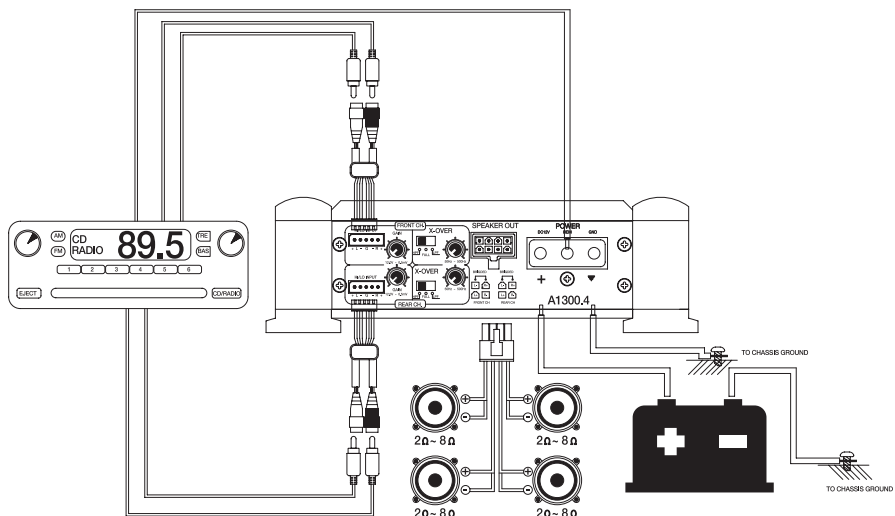

LOW INPUT MODE

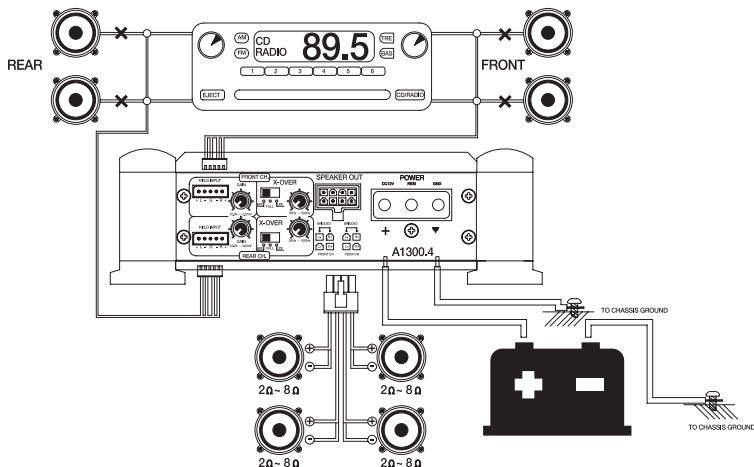

HIGH INPUT MODE

A1300.4		
120Wx4ch	40hm.	14.4V 1Khz RMS.
150Wx4ch	20hm.	14.4V 1Khz RMS.
325Wx2ch	40hm.	14.4V 1Khz RMS.

These amplifiers are designed to work within a 10 to 16.8 volt DC range. Before any wires are connected, the vehicles electrical system should be checked for correct voltage supply with the help of a voltmeter.

First, check the voltage at the battery with the ignition in the OFF position. The voltmeter should read not less than 12V. If your vehicles electrical system is not up to these specifications, we recommend having it checked by an auto electrician before any further installation. Once the vehicle is checked, make certain the correct cable size is used. We recommend using as large a gauge cable as possible, use the Power Cable Selection Chart to calculate the correct power wire size for your application.

Power

This amplifier should be wired directly to the vehicle battery using the appropriate size cable. Start at the vehicle battery and run the power cable through to the amplifier. Avoid running the power cable over engine components and near heater cores. The use of an inline fuse or circuit breaker is a must ; this will prevent the risk of a potential fire caused by a short in your power cable. Connect the fuse holder or circuit breaker as close to the battery positive (+) terminal as possible (no farther then 18" from the battery).This fuse or circuit breaker should be no greater then the sum of the fuses found on the chassis of your amplifier (also see specifications chart). You may now connect the cable to the battery, but remember to leave the fuse out or circuit breaker "off" until all other cable connections are made.

Ground

When grounding your amplifier, locate a metal area close to the amplifier that is good source of ground (preferably the floor pan). Once again, investigate the area you wish to use for electrical wires, vacuum lines, and brake or fuel lines. Use either a wire brush or sandpaper to eliminate unwanted paint for better contact of the ground. Secure the ground cable to the body using a bolt, star washer and nut. Spread silicon over the wcrew and bare metal to prevent rust and possible water leaks.

Now it's time to connect the power and ground cable to the amplifier. Cut both cables to length. Strip off 1/2 -inch (12mm) of the insulation so that the bare wire will go all the way in the terminal block on the side panel of the amplifier, seating it firmly so no bare wire is exposed. Use a Philips (cross) type screwdriver to loosen the + BATT and the GND connections on the amplifier. Insert the ground first, and then the + 12V and please make sure that you place them into the correctly marked terminals.

Then tighten the screws down securely.

Remote

This terminal must be connected to a switched +12V source. Typically, remote turn-on leads are provided at the source unit that will turn on and off the amplifier in correspondence with the source.

If the source unit does not have a remote turn-on lead, then a switched +12V supply must be used, like the ACC, +12v.

**LIMITED 90-DAY CONSUMER WARRANTY
LIMITED TWO-YEAR CONSUMER WARRANTY WITH PURCHASE AND INSTALLATION BY
A PRECISIONPOWER
AUTHORIZED DEALER**

Precisionpower promises to the original purchaser, to repair or replace this product with a new or refurbished unit (at Precisionpower's sole and absolute discretion) should it prove to be defective in workmanship or material under normal use, for a period of *two-years from the date of purchase from the Precisionpower authorized dealer, PROVIDED the product was purchased and installed by a Precisionpower authorized dealer. During this *two-year period, there will be no charge for product repair or replacement, PROVIDED the unit is returned to Precisionpower, return shipping pre-paid, along with the required proof of installation, the bill of sale or other dated proof of purchase, and the consumer's contact information.

If the unit is installed by anyone other than a Precisionpower authorized dealer, the warranty period will be 90-days from the date of purchase. This warranty is non-transferable and does not apply to any unit that has been modified or used in a manner contrary to its intended purpose, and does not cover damage to the unit caused by installation or removal of the unit. During this 90-day period, there will be no charge for the repair or replacement PROVIDED the unit is returned to Precisionpower, return shipping prepaid, along with the bill of sale or other dated proof of purchase and the consumer's contact information.

This warranty is void if the product has been damaged by accident or unreasonable use, neglect, improper service or other causes not arising out of defects in materials or construction. This warranty does not cover the elimination of externally generated static or noise, or the correction of antenna problems or weak reception, damage to speakers, accessories, electrical systems, cosmetic damage or damage due to negligence, misuse, failure to follow operating instructions, accidental spills or customer applied cleaners, damage due to environmental causes such as floods, airborne fallout, chemicals, salt, hail, lightning or extreme temperatures, damage due to accidents, road hazards, fire, theft, loss or vandalism, damage due to improper connection to equipment of another manufacturer, modification of existing equipment, or Product which has been opened or tampered for any reason. Units which are found to be damaged by abuse resulting in thermally damaged voice coils are not covered by this warranty but may be replaced at the absolute and sole discretion of Precisionpower. Unit must be returned to Precisionpower, postage pre-paid, with bill of sale or other dated proof of purchase bearing the following information: consumer's name, telephone number, and address, authorized dealer's name and address, and product description. Please contact Precisionpower warranty office at 800-724-1377 or repairs@precisionpower.com to obtain a Return Authorization number prior to shipping the product.

Note: This warranty does not cover labor costs for the removal and reinstallation of the unit. IN ORDER FOR THE TWO-YEAR WARRANTY TO BE VALID, YOUR UNIT MUST BE SHIPPED WITH PROOF OF INSTALLATION BY A PRECISIONPOWER AUTHORIZED DEALER. ALL UNITS RECEIVED BY PRECISIONPOWER FOR WARRANTY REPAIR WITHOUT PROOF OF PRECISIONPOWER AUTHORIZED DEALER INSTALLATION AND PURCHASE WILL BE COVERED BY THE LIMITED 1 YEAR WARRANTY.

BY PURCHASING THIS PRODUCT, ALL WARRANTIES INCLUDING BUT NOT LIMITED TO EXPRESS WARRANTY, IMPLIED WARRANTY, WARRANTY OF MERCHANTABILITY, FITNESS FOR PARTICULAR PURPOSE, AND WARRANTY OF NON-INFRINGEMENT OF INTELLECTUAL PROPERTY ARE EXPRESSLY EXCLUDED TO THE MAXIMUM EXTENT ALLOWED BY LAW, AND PRECISIONPOWER NEITHER ASSUMES NOR AUTHORIZES ANY PERSON TO ASSUME FOR IT ANY LIABILITY IN CONNECTION WITH THE SALE OF THE PRODUCT. PRECISIONPOWER HAS ABSOLUTELY NO LIABILITY FOR ANY AND ALL ACTS OF THIRD PARTIES INCLUDING ITS AUTHORIZED DEALERS OR INSTALLERS. BY PURCHASING THIS PRODUCT, THE CONSUMER AGREES AND CONSENTS THAT ALL DISPUTES BETWEEN THE CONSUMER AND PRECISIONPOWER SHALL BE RESOLVED IN ACCORDANCE WITH CALIFORNIA LAWS IN LOS ANGELES COUNTY, CALIFORNIA.

Some states do not allow limitation on how long an implied warranty lasts. In such states, the limitation or exclusions of this Limited Warranty may not apply. Some states do not allow the exclusion or limitation of incidental or consequential damages. In such states, the exclusion or limitation of this Limited Warranty may not apply to you. This Limited Warranty gives you specific legal rights, and you may have other rights which vary from state to state.



*Precision***Power**

Absolutely State of the Art Mobile Audio™