

POWERCLASS™

PC2100 / PC2200 / PC2300 OWNER'S MANUAL



100%

CONTENTS

(click on a topic to view)

- ⚡ CONGRATULATIONS
- ⚡ FEATURES / SPECIFICATIONS
- ⚡ INSTALLATION
- ⚡ WIRING
- ⚡ WIRING (continued)
- ⚡ POWER / GROUND
- ⚡ SPEAKER WIRING
- ⚡ END PLATE DIAGRAM
- ⚡ INPUTS
- ⚡ QBASS / CROSSOVER
- ⚡ AMPLIFIER ADJUSTMENTS
- ⚡ TROUBLE SHOOTING
- ⚡ SYSTEM DIAGRAM ONE
- ⚡ SYSTEM DIAGRAM TWO
- ⚡ SYSTEM DIAGRAM THREE
- ⚡ SYSTEM DIAGRAM FOUR
- ⚡ BLOCK DIAGRAM
- ⚡ WARRANTY

Congratulations and thank you.....

for choosing *PrecisionPower* audio equipment. At *PrecisionPower* we proudly design, engineer and manufacture audio products at our facility in Phoenix, Arizona. Our award winning engineering team utilizes innovative technology to consistently deliver Absolutely State of the Art™ performance, sound quality, reliability, and value. This *PrecisionPower* product reflects our commitment to offer you unparalleled versatility and quality for years of dependable service and listening enjoyment.

Service



Do not attempt to service *PrecisionPower* products yourself. Performing exploratory surgery on your audio equipment yourself will void the warranty. Many parts of your *PrecisionPower* gear are custom built to our specifications. Our factory parts are not made available to anyone else nor are they for sale. Our goal is to make sure that your *PrecisionPower* product will always sound as good as the day it was purchased. Contact your authorized *PrecisionPower* dealer about obtaining any warranty service through *PrecisionPower*. (See Warranty inside back cover)

FOR YOUR RECORDS:

M o d e l _____

Serial Number _____

Purchase Date _____

Caution!



The extended use of a high powered audio system may result in hearing loss or damage. While *PrecisionPower* systems are capable of "Concert Level" volumes with incredible accuracy, they are also designed for you to enjoy at more reasonable levels all of the sonic subtleties created by musicians. Please observe all local sound ordinances.

FEATURES / SPECIFICATIONS

Adaptive MOSFET Switching Power Supply
Fully Complimentary Darlington Output Stage
AP III Protection Circuitry
QBASS™ Bass Boost
Two Way 90 Hz Crossover with Line Outputs
Balanced Differential Input Stage
High Voltage Input Capability with Input Attenuation Switch
Gold Plated RCA Input and Output Connectors
PowerLock Speaker and Power Wire Connectors
Mixed Mono/Stereo Operation
Three Year Warranty when installed by an Authorized **PrecisionPower** Dealer
Completely Designed And Handcrafted In The USA

Specifications



| | |
|----------------------------|---------------------------|
| Power Bandwidth: | 4.5 Hz - 100 kHz |
| Total Harmonic Distortion: | 0.02 % |
| Input Topology: | Balanced Differential |
| Input Sensitivity: | 120mv - 12 volts RMS |
| Input Impedance: | 10k Ohms |
| Load Impedance (stereo) | 2 - 8 Ohms |
| Load Impedance (bridged) | 4 - 8 Ohms |
| Supply Voltage | 11 - 15 volts |
| Damping Factor | >500 |
| Slew Rate | >50 V/μS |
| QBASS™ Equalization | Up To +12dB Boost @ 40 Hz |
| Idle Current: | .7 Amps |

Dimensions

| | |
|----------|----------------|
| Length - | PC2100 - 7.45" |
| | PC2200 - 9.72" |
| | PC2300 -11.72" |
| Height - | All - 2.25" |
| Width - | All - 8.9" |

Crossover Specifications



Crossover Point: 90 Hz
Choice of High Pass or Low Pass at RCA outputs while opposite is available at the Speaker Outputs.
PC2100 - Third Order (18 dB/octave), Butterworth alignment fixed at 90 Hz.
PC2200/PC2300 - Fourth Order (24 dB/octave), Linkwitz-Riley alignment fixed at 90 Hz.

Continuous Output Power



PC2100

25 WRMS x 2 @ 4Ω per channel
50 WRMS x 2 @ 2Ω per channel
100 WRMS x 1 @ 4Ω bridged

PC2200

50 WRMS x 2 @ 4Ω per channel
100 WRMS x 2 @ 2Ω per channel
200 WRMS x 1 @ 4Ω bridged

PC2300

75 WRMS x 2 @ 4Ω per channel
150 WRMS x 2 @ 2Ω per channel
300 WRMS x 1 @ 4Ω bridged

INSTALLATION

Tools/Parts needed for Installation (not supplied)



- Small flat blade screwdriver
- Phillips Screwdriver (#2 or medium sized)
- Wire cutters
- Wire strippers
- 4 - #6 round head screws, and 1 - #8 sheet metal screw (or nut, bolt, and star washer)
- 2 - Ring connectors (large enough to accommodate your method of grounding)
- In-line fuse or circuit breaker - see fuse chart below
- Power and ground wire - see Power Wire Calculator on page 3
- Speaker wire - 16 gauge or larger
- Grommets (sized to work with the power wire you plan to use in your installation)
- Tube of silicone sealant

Fuse requirements



| Amplifier | Maximum Fuse Rating |
|---------------|---------------------|
| <i>PC2100</i> | 20 Amp |
| <i>PC2200</i> | 30 Amp |
| <i>PC2300</i> | 35 Amp |

You will need to install an in-line fuse or circuit breaker in the power wire within 18" of the battery. This fuse or circuit breaker is to protect your vehicle from fire in case the power wire shorts to the vehicle body. If you are only using one amplifier, use the fuse rating indicated in this chart. If you are using more than one amplifier, add up the fuse ratings for all the amplifiers. This sum is the rating for your fuse or circuit breaker. You may also want to add a power distribution block near your amplifiers to keep the wiring tidy.

WIRING

The following is a basic formula to be used as a guide to determine amperage draw. A 50% amplifier efficiency rating is used as an average. Your new **POWERCLASS™** amplifier is more efficient, other amplifiers will probably be less. This formula is to be used as a guideline. Using wire of a larger gauge can only improve the current transfer of your system. Do not use smaller gauge wire.

Total RMS output x 2 = Total Input Wattage

$$\frac{\text{Total Input Wattage}}{\text{Supply Voltage}} = \text{Current Draw (in Amps)}$$

Example: A **POWERCLASS™** 2200 amplifier has two channels at 50 watts per channel RMS rating into 4 Ohms (50 + 50 = 100). You would use the formula in the following way:

$$100W \times 2 = 200W$$

$$\frac{200W}{12V} = 16.7A \text{ Total amperage draw.}$$

If the same amplifier is driven into a 2 Ohm stereo or 4 Ohm mono load, double its 4 Ohm RMS rating. All **POWERCLASS™** amplifiers will effectively double their power at this load.

$$100W \times 2 \times 2 = 400W$$

$$\frac{400W}{12V} = 33.3A \text{ Total amperage draw.}$$

If you are using more than one amplifier, add up the total amperage draw for all of them and choose the appropriate gauge based on the grand total.

Power Wire Calculator



Recommended MINIMUM Gauge

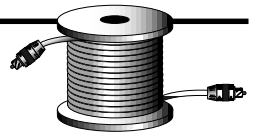

| Total Current Draw (in Amps) | Length Of Wire To Be Run | | | | | | | |
|----------------------------------|--------------------------|-----------|------------|-------------|-------------|-------------|-------------|-------------|
| | Up to 4ft. | 4 to 7ft. | 7 to 10ft. | 10 to 13ft. | 13 to 16ft. | 16 to 19ft. | 19 to 22ft. | 22 to 28ft. |
| 0-20 | 14 | 12 | 12 | 10 | 10 | 8 | 8 | 8 |
| 20-35 | 12 | 10 | 8 | 8 | 6 | 6 | 6 | 4 |
| 35-50 | 10 | 8 | 8 | 6 | 6 | 4 | 4 | 4 |
| 50-65 | 8 | 8 | 6 | 4 | 4 | 4 | 4 | 2 |
| 65-85 | 6 | 6 | 4 | 4 | 2 | 2 | 2 | 0 |
| 85-105 | 6 | 6 | 4 | 2 | 2 | 2 | 2 | 0 |
| 105-125 | 4 | 4 | 4 | 2 | 2 | 0 | 0 | 0 |
| 125-150 | 2 | 2 | 2 | 2 | 0 | 0 | 0 | 00 |

NOTE: The ground wire should be the same gauge as the power wire.

WIRING

Before beginning, disconnect the negative (-) terminal of the battery prior to working on the positive (+) terminal to prevent a short to ground. This is important, unless you want to spend the rest of your life with a nickname like "Sparky," or "Smokey." Reconnect the negative terminal only after all connections have been made.

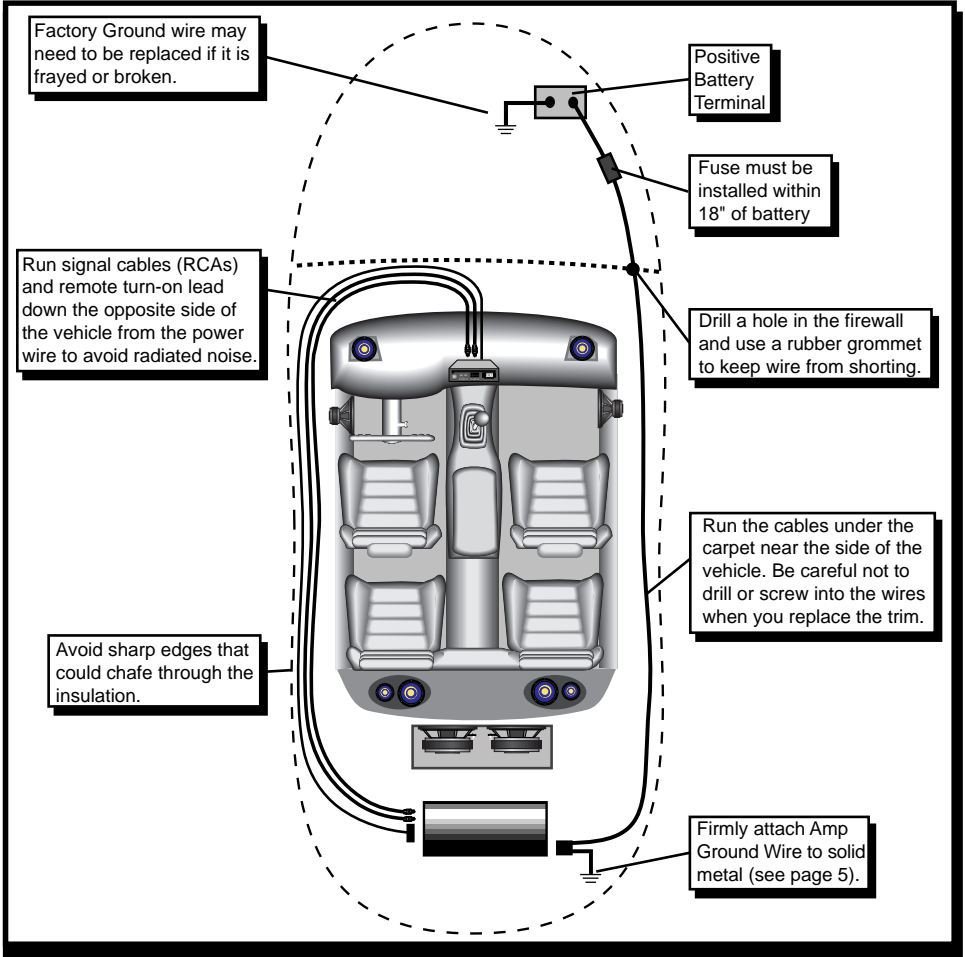

Warning!

Fuse must be installed within 18" of battery

POWER / GROUND

Locate an area near the amplifier(s) that is metal and clean an area about the size of a quarter to bare metal. Inspect the area around and underneath to be sure you won't drill into wires, brake or fuel lines, etc. Drill a pilot hole into the middle of this area. Terminate the ground wire with a ring connector and attach it to the bare metal using a #8 sheet metal screw and washer or preferably, a bolt, nut and a star washer (not supplied). We suggest crimping and soldering this connection. After the connection is complete, coat the area (on both sides) with silicone or some similar material to prevent rust from developing on the bare metal.

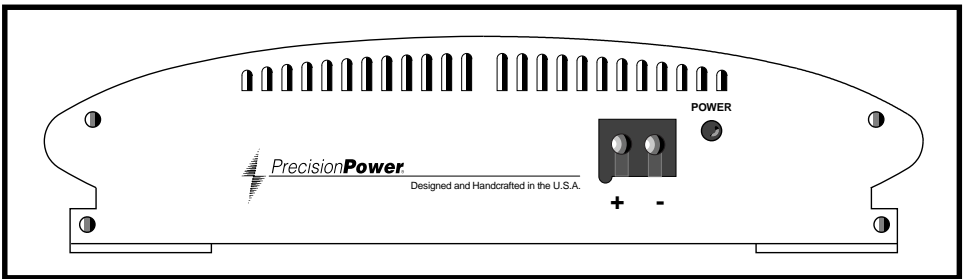

Once you have run both the power and ground wires, it's time to connect the cables to the amplifier. Cut off excess wire and, using wire strippers, strip the ends of the power and ground cables approximately 1/4 inch. Locate the **PowerLock** power and ground connector (supplied). With a small flat bladed screw driver, loosen the screws before attempting to insert the cables. Insert the wires into the appropriate hole, and tighten the screws. Once the wires are secure, the **PowerLock** may be plugged into the amplifier.

Power/Ground **PowerLock**

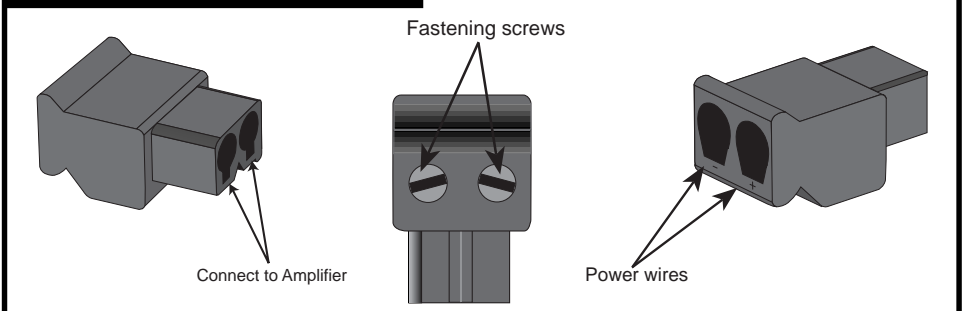

SPEAKER WIRING

Using 16 gauge or larger, run the speaker wires from the amplifier location through the vehicle to the speakers. Observe the same precautions for routing these wires that you followed for running the power and remote turn-on wires. Cut off excess and, using wire strippers, strip 1/4 inch of insulation. Locate the speaker/remote turn-on **PowerLock** connector. Loosen the four outer screws on the underside of the connector. Insert the speaker leads into the end. Check to be sure you've maintained proper polarity before securing each wire.

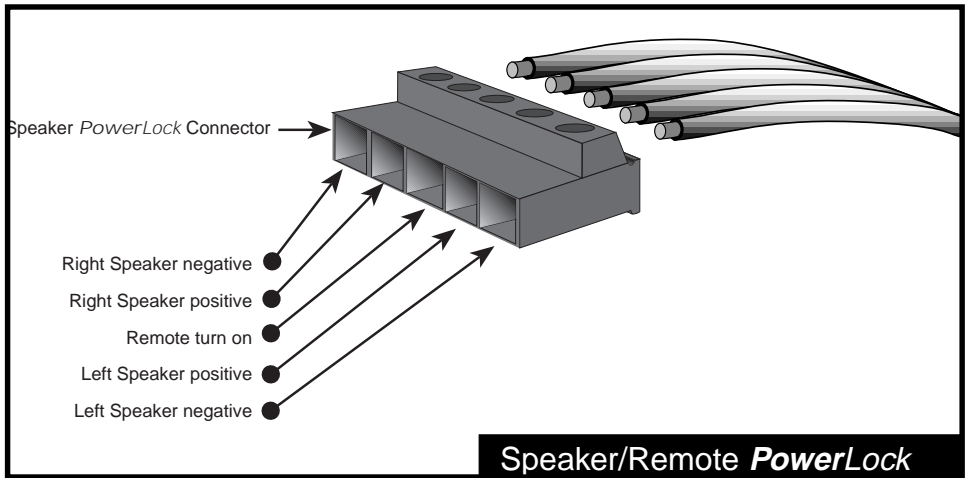

ENDPLATE DIAGRAM

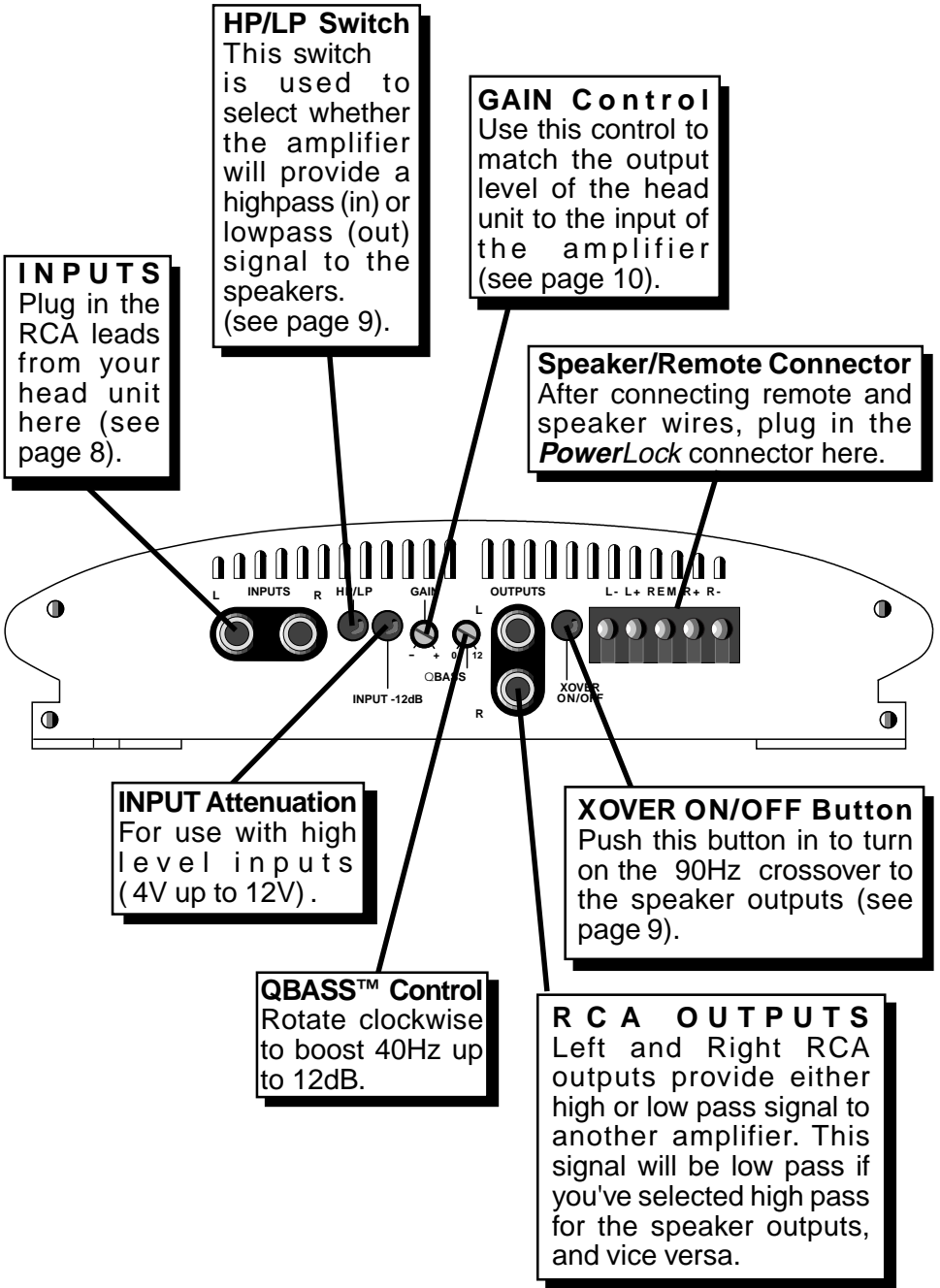

INPUTS

There are two sets of RCA jacks on the front end of your amplifier. The RCA cables from your head unit go in the set labeled INPUTS. If your head unit doesn't have RCA outputs don't worry. Simply add a set of RCA plugs (available at your dealer) to your front or rear set of speaker leads (see drawing below), plug them into the input jacks, and push in the INPUT ATTENUATION button.

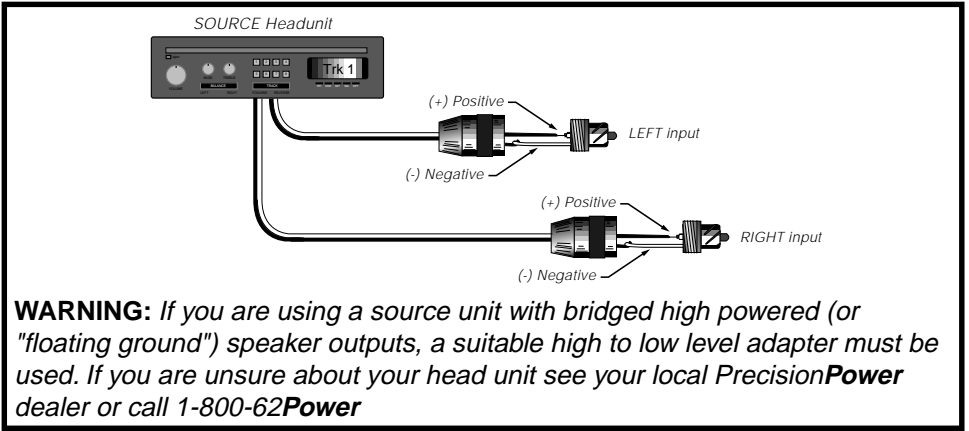

Balanced Differential Inputs



This circuitry is capable of eliminating noise radiated into your signal cables by up to 40dB. This is equivalent to a noise reduction of approximately one hundred times what the noise level would be without this circuitry. It provides all the benefits of a true 'balanced' line without the need of any special cables (see diagram below). This type of input works with any

conventional RCA cable.

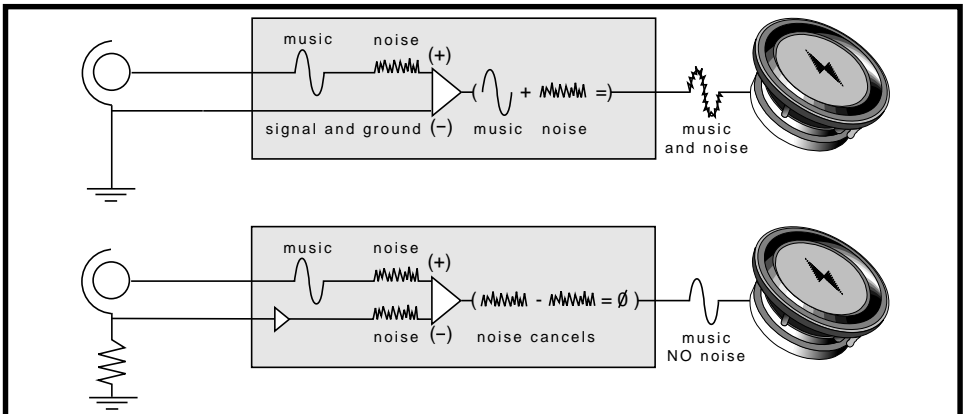

QBASS™ and CROSSOVER Operation

QBASS™



For extra BOOM from your system, we've developed the **QBASS™** bass control circuit. The **QBASS™** control is located to the left of the RCA outputs, and allows you to add up to 12dB of boost centered at 40Hz by rotating the control clockwise.

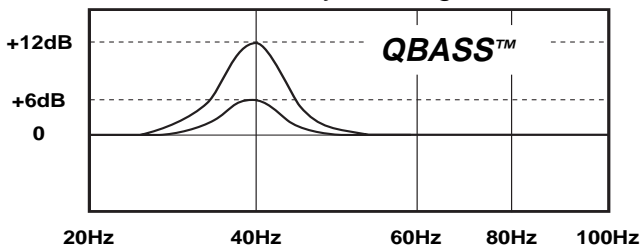

CAUTION: **QBASS™** should only be used in systems with strong subwoofers. 12dB is a lot of bass boost and could damage full range speakers.

Crossover



Your new **POWERCLASS™** amplifier has a 90Hz crossover built in to provide system flexibility without the added expense and installation of an outboard crossover. The **PC2100** has a third-order Butterworth type 18dB per octave crossover, and the **PC2200** and **PC2300** house a fourth-order Linkwitz-Riley type, 24dB per octave phase correlated crossover for a tighter sound. The speaker outputs of your amplifier are high pass or low pass according to the HP/LP switch adjacent to the inputs. You would choose low pass (switch out) to use this amp for subwoofers, or choose high pass (switch in) to use this amp for full range speakers. The RCA outputs are controlled by the same HP/LP switch, but are always the inverse of the speaker output crossover. If the HP/LP switch is out (LP) the RCA outputs will be high pass, and if the HP/LP switch is in (HP) the RCA outputs will be low pass. In addition, the speaker outputs can be all pass (no crossover) by setting the Xover ON/OFF switch to the off (out) position.

NOTE: The RCA outputs are always crossed over. The System Diagrams beginning on page 12 show several ways to use the internal crossover in your system.

AMPLIFIER ADJUSTMENT

Adjusting The Amplifier Input Gain



1. Adjust all amplifier input gain controls to just above minimum sensitivity (fully counterclockwise).
2. Using the cleanest source (CD), with music playing turn up the head unit until you can hear distortion. Now turn it down a bit until you cannot hear the distortion.
3. Increase the Amplifier gain (clockwise) until the onset of audible distortion. Then decrease the gain to the point just before the distortion starts. This setting minimizes background noise and prevents overload.
4. Repeat step 3 for any remaining amplifiers in the system.

Bridging



All two-channel **POWERCLASS™** amplifiers are capable of being bridged into a 4 ohm mono output without switches or bridging modules. This feature permits the creation of a mono channel for a subwoofer or center channel.

Deriving the mono channel is accomplished by using the left channel positive wire as the positive speaker wire and the right channel negative wire as the negative speaker wire. It is important that a minimum 4 ohms impedance is observed. If the impedance drops significantly below 4 ohms while the amplifier is wired in the bridged configuration, the amplifier's protection circuitry (AP III) may engage.

Heatsink Cooling



The unique heatsink on your **POWERCLASS™** amplifier has been designed with fins on the inside of the aluminum mass. This allows for the transfer of heat from the circuitry to the heatsink fins and out through the vents in the endplates. Be sure you have ample space around the amplifier for cooling, at least 2" on all sides.

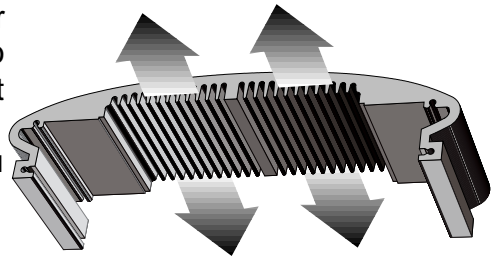

TROUBLE SHOOTING

NO SOUND

Is the LED lit?

YES



STILL NO SOUND - See your Authorized *PrecisionPower* Dealer or Call 1-800-62**POWER**.

NO

Check Power and Remote turn-on wire for voltage. Make sure Ground wire is secure.

SOUND IN ONE CHANNEL ONLY

Reverse left and right speakers by unplugging the speaker connector, turning it over and plugging it back in.

SOUND IS NOW IN

OPPOSITE CHANNEL

Reverse RCA inputs

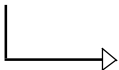

SOUND IS NOW IN

SAME CHANNEL

Problem is in the speaker or speaker wire of the silent channel.

OPPOSITE CHANNEL

Reverse RCAs at head unit



SOUND IS NOW IN

SAME CHANNEL

Problem is in the Amplifier. See your local Authorized *PrecisionPower* Dealer or call 1-800-62**POWER**.

OPPOSITE CHANNEL

Problem is in the head unit

SAME CHANNEL

Problem is in the RCA cables

AMPLIFIER SHUTS OFF

Short Circuit Protection engaged:

The amplifier will turn off and try to come back on immediately. The amplifier will cycle like this indefinitely, with "blips" of sound each time. If this is the case, check your speakers and wiring for low impedance and short circuits.

Thermal Protection engaged:

The amplifier will turn off and several minutes later will come back on. In this case, ensure that there is nothing blocking the normal convective airflow of the amplifier. No obstruction should be within 2" of the amplifier on all sides.

SYSTEM DIAGRAM

ONE

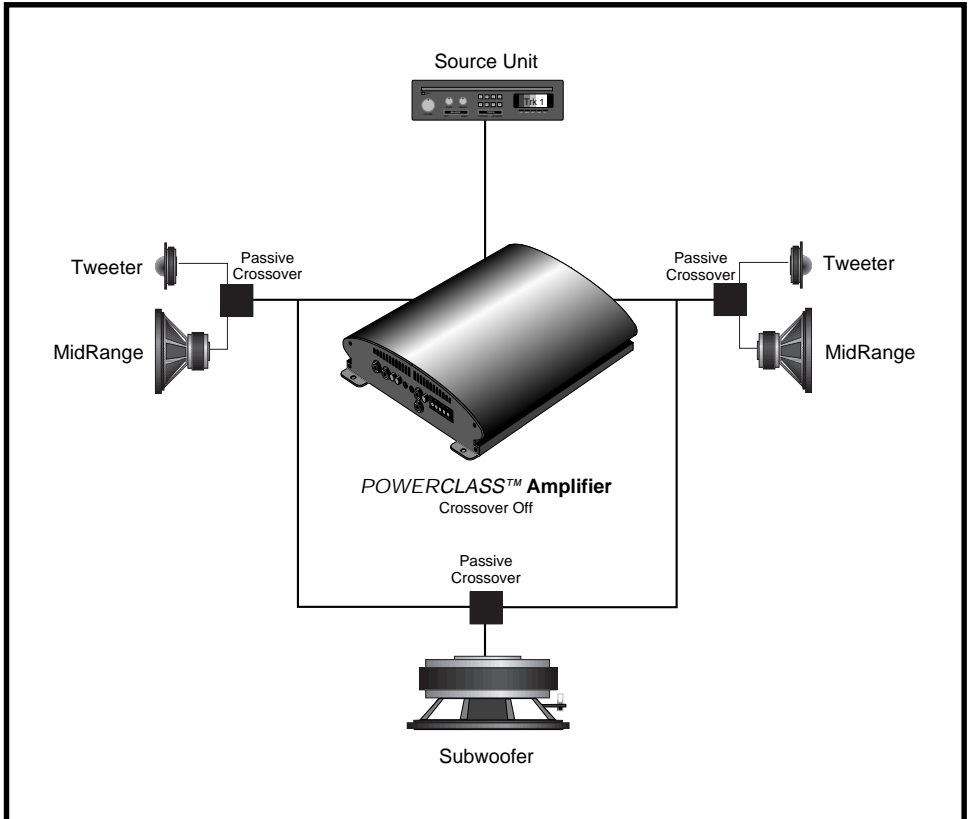

Mixed Mono Output

The ability to run stereo speakers while simultaneously running a mono output from the same amplifier is accomplished by running the stereo speakers normally and tapping into the appropriate wires for the "mixed mono" channel (left channel positive for the positive speaker wire and right channel negative for the negative speaker wire). Speaker impedance should be no lower than 2 ohms on the stereo channels and 4 ohms on the mono channel.

NOTE: Passive crossovers must be used for "mixed mono" operation. Choose a low pass crossover around 100Hz for your subwoofer, then choose a high pass crossover for your stereo channels. The high pass crossover must be at the same or slightly higher frequency than the low pass crossover to maintain the correct impedance. See your *PrecisionPower* dealer or call 1-800-62**POWER** for more information about passive crossovers.

SYSTEM DIAGRAM

TWO

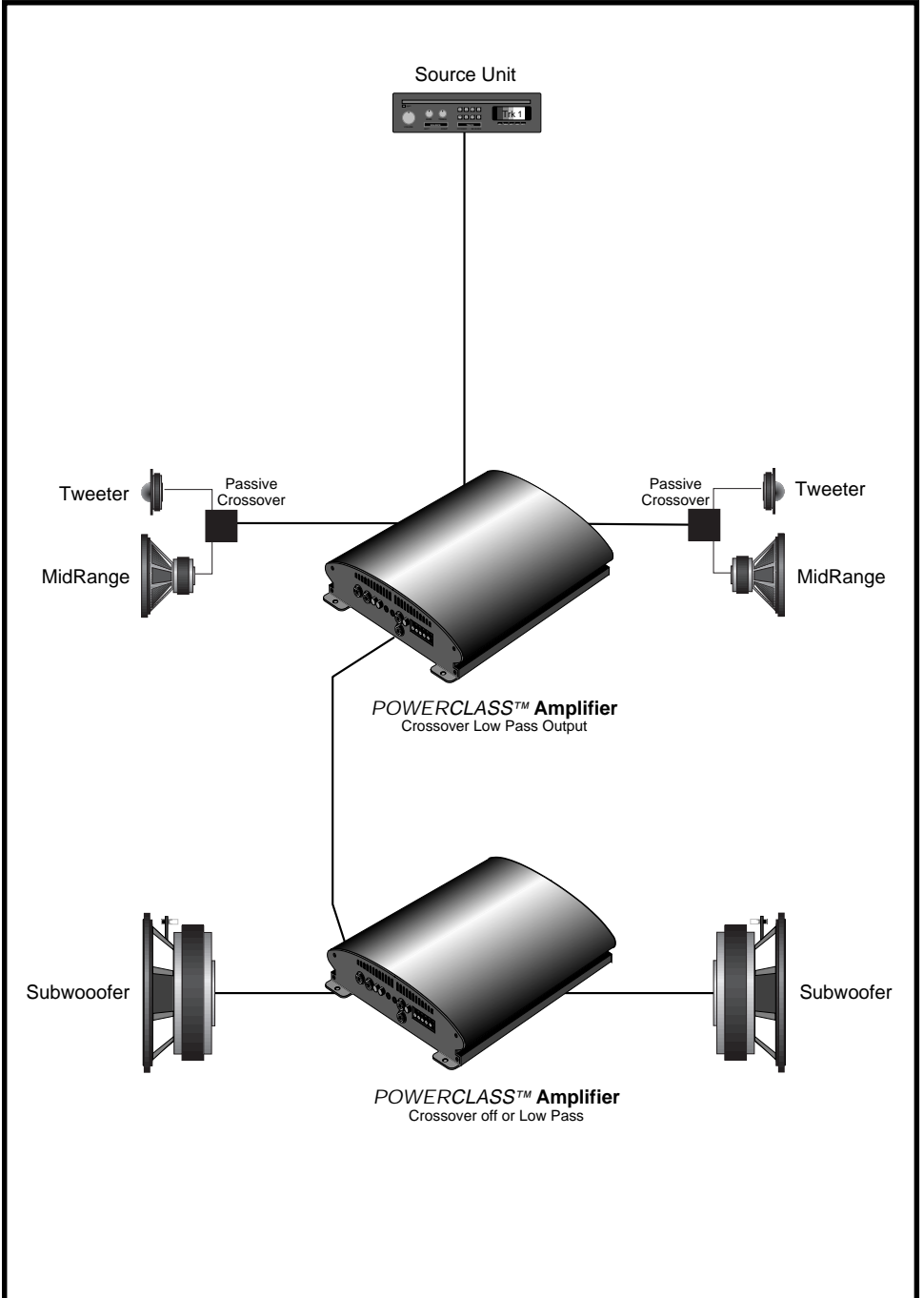

SYSTEM DIAGRAM THREE

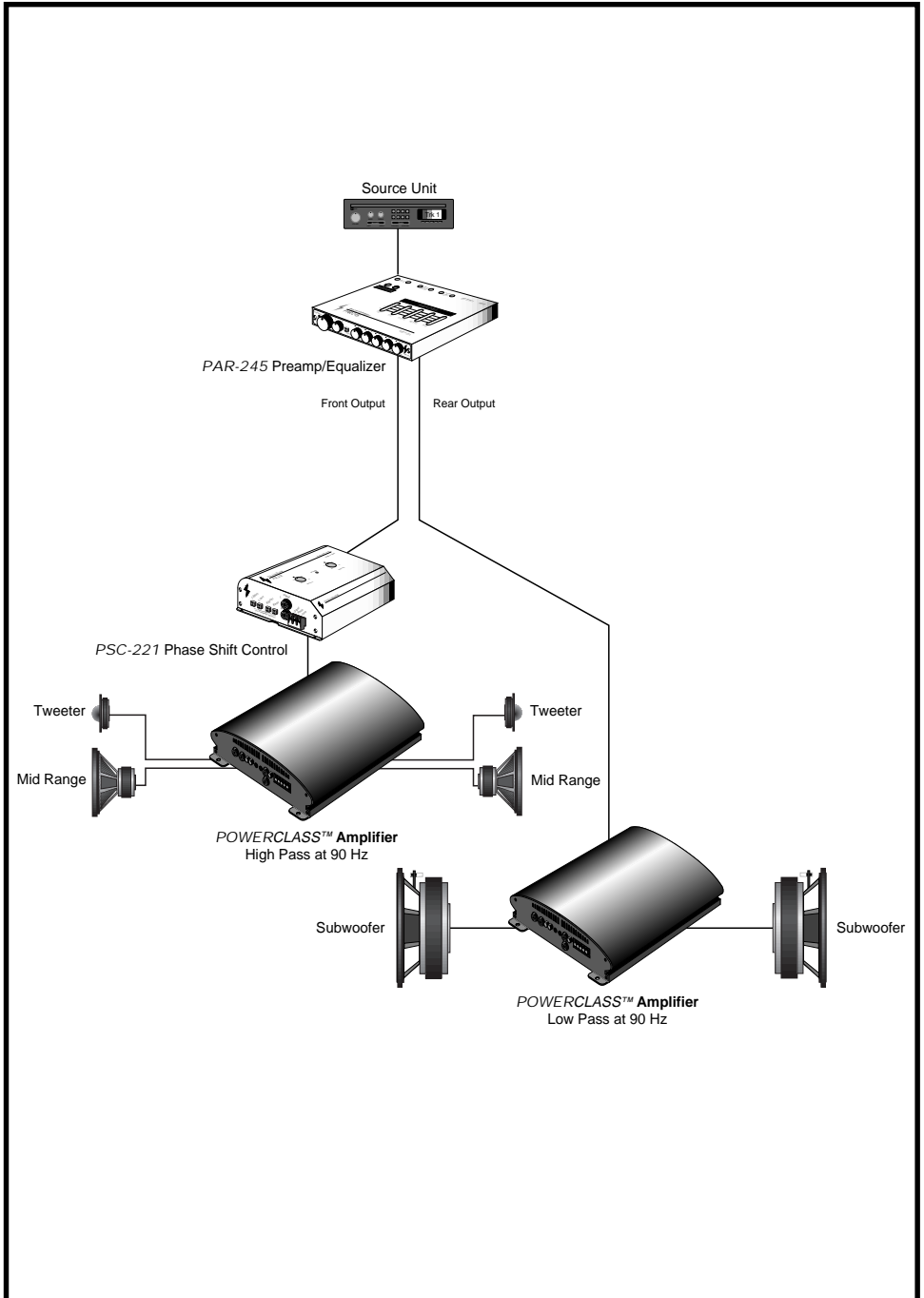

SYSTEM DIAGRAM

FOUR

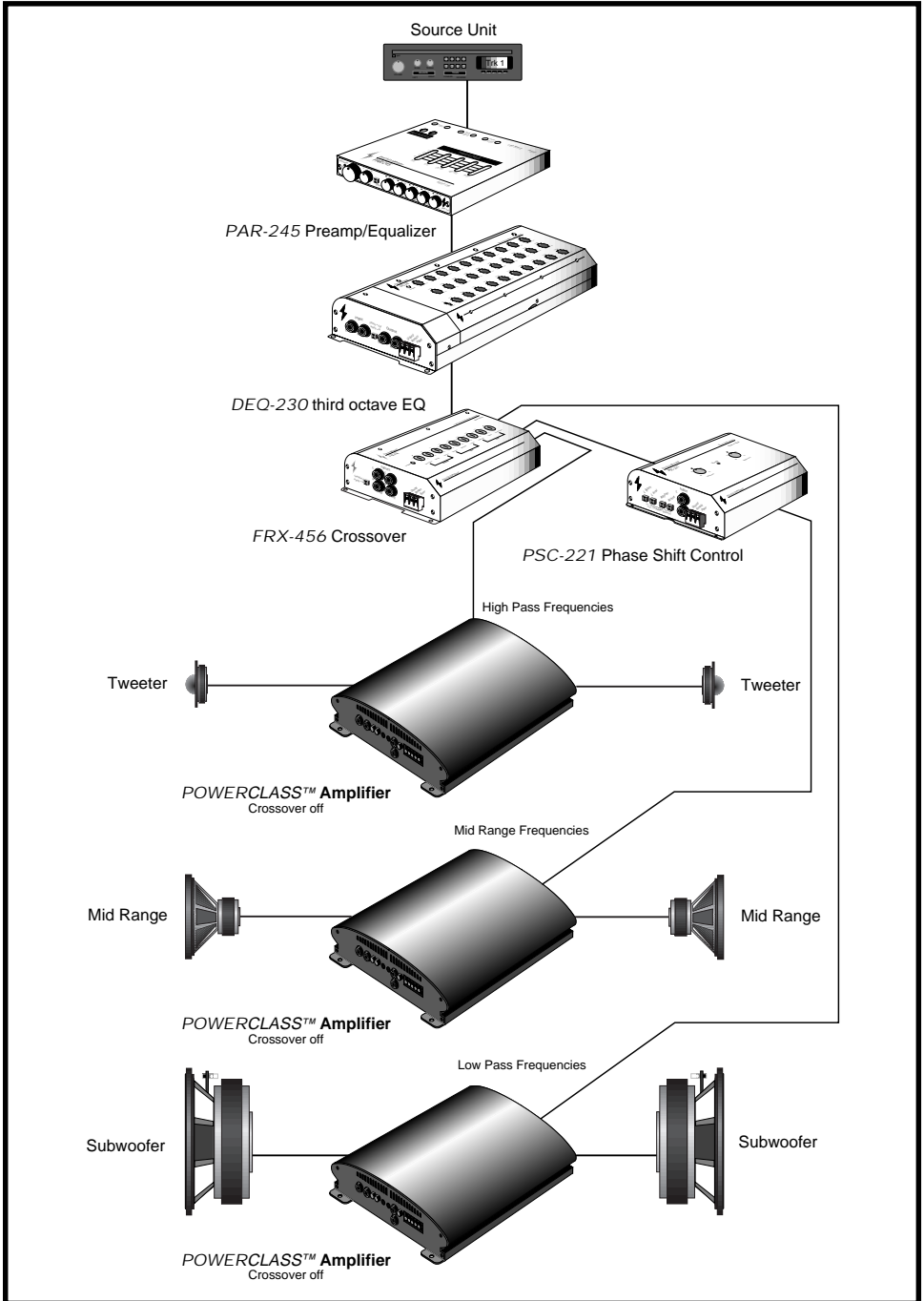

BLOCK DIAGRAM

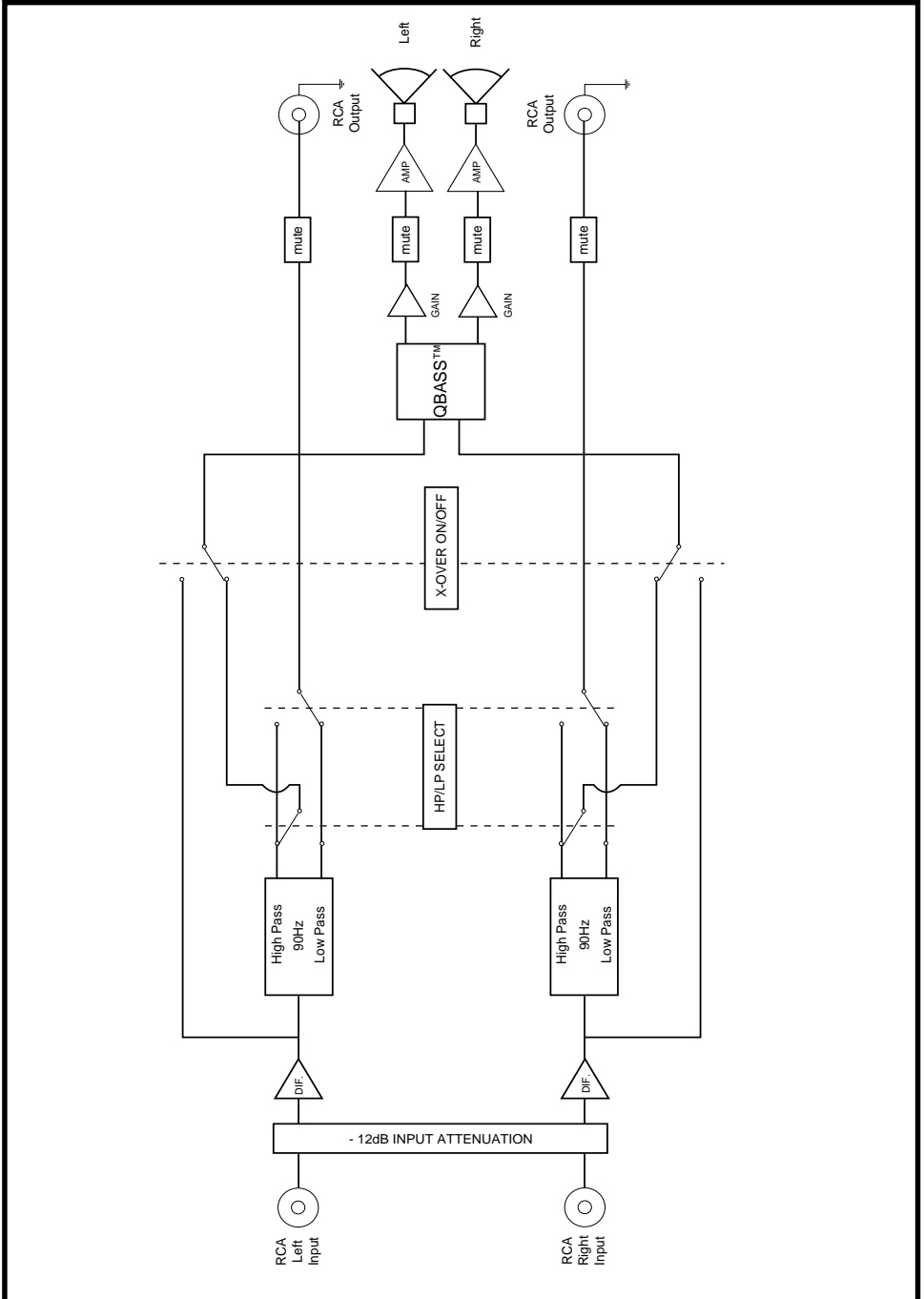

WARRANTY

Three-Year Limited U.S.A. Warranty

This warranty gives you specific legal rights, and you may also have other rights which vary from state to state. **PrecisionPower** warrants its products to be free from defects in materials and workmanship under normal use and service for a period of three (3) years from the date of original purchase when the unit is installed by an Authorized Dealer. Non-Authorized Dealer installed products carry a one (1) year parts and ninety (90) days labor limited warranty. The extent and conditions of Limited Warranty are as follows:

1. Authorized Dealer Installed Products: **PrecisionPower** will either repair or replace at no charge, to the original purchaser, any unit which **PrecisionPower's** examination discloses to be defective and under warranty, provided the defect occurs within three (3) years from the date of original purchase when the unit is installed by an Authorized Dealer and the product is returned immediately to **PrecisionPower**. This warranty is not transferable.

2. Non-Authorized Dealer Installed Products: **PrecisionPower** will either repair or replace at no charge, to the original purchaser, any unit which **PrecisionPower's** examination discloses to be defective and under warranty, provided the defect occurs within ninety (90) days from the date of purchase and the product is returned immediately to **PrecisionPower**. Warranty claims beyond ninety (90) days for Non-Authorized Dealer Installed Products will be for parts only and will extend for one (1) year from the date of purchase. This warranty is not transferable.

3. The date of purchase and proof of Authorized Dealer Installation of a PrecisionPower product must be established by an original sales receipt which must accompany the article being returned for warranty work.

4. This warranty shall NOT apply to any **PrecisionPower** product found to have the original factory serial number removed or defaced. All products received (by **PrecisionPower**) for in-warranty or out of warranty repair, with their original serial numbers removed or defaced, will NOT be repaired and will be returned to sender, freight collect. Refer to original packaging for the serial number of your component speakers.

5. The provisions of this warranty shall not apply to any **PrecisionPower** product used for a purpose for which it is not designed, which has been repaired or altered in any way, or which has been connected, installed, or adjusted other than in accordance with the instructions furnished in **PrecisionPower's** owner's manual. Nor shall this warranty apply to any part which has been subject to misuse, neglect, or accident.

6. PrecisionPower does not authorize any other persons to assume any other liability in connection with its products. THIS WARRANTY IS THE ONLY EXPRESS WARRANTY MADE BY PRECISIONPOWER APPLICABLE TO ITS PRODUCTS. ANY IMPLIED WARRANTY OR MERCHANTABILITY OR FITNESS FOR A PARTICULAR PURPOSE APPLICABLE TO PRECISIONPOWER PRODUCTS IS LIMITED IN DURATION TO THE DURATION OF THIS LIMITED WARRANTY. PRECISIONPOWER SHALL NOT BE LIABLE FOR THE INCIDENTAL, CONSEQUENTIAL, OR COMMERCIAL DAMAGES RESULTING FROM THE BREACH OF THIS WRITTEN WARRANTY. Some states or provinces do not allow the exclusion or limitation of incidental or consequential damages or limitations on how long an implied warranty lasts; so the above limitations or exclusions may not apply to you.

7. Your product will be serviced on an in-warranty basis within the warranty period for the correction of warranted defects. If improper operation of your **PrecisionPower** product should occur, contact your Authorized Dealer for assistance with the return and factory repair of your **PrecisionPower** product. If an Authorized Dealer is not available, return the unit including your name, telephone number, return address, a copy of your sales receipt, and a description of the problem to:

PrecisionPower, Inc.
Service Department
4829 S. 38th Street
Phoenix, AZ 85040-2964

TO RETURN PRECISIONPOWER PRODUCTS OUT OF WARRANTY: Return the unit, postage prepaid, in the original protective carton. Please include a description of the problem and, if desired, a request for an estimate of repair costs. Unless a request for an estimate is included, the unit will be repaired as necessary. Please contact **PrecisionPower** Customer Service at 1-800-62-POWER for questions concerning out of warranty repair charges. Repaired unit will be returned with an itemized statement, C.O.D.