

Caution:

Please do not plug in or unplug RCA plugs to the amplifier inputs while the amplifier is turned on. Doing so is potentially harmful to the amplifier by allowing RF (radio frequencies) into the amplifier, causing instability during the brief period while the RCA shield is not connected, and the power is connected. Only plug in or unplug RCA plugs with the amplifier off as standard practice with all audio equipment.

*Precision***Power**[®]

Absolutely State of the Art Mobile Audio

Owner's Manual and
Installation Guide

BK120.2

BK210.2

BK340.2

BK340.4

BK520.4

Black Ice

BK800.4

Series

BK580.5

BK650.1D

BK1300.1D

BK1800.1D

CONGRATULATIONS

Thank you for choosing Precision**Power** audio equipment. Designed and engineered in the USA, this product combines innovative technology with the finest materials to consistently deliver Absolutely State of the Art™ performance, sound quality, reliability, and value. This Precision**Power** product reflects our commitment to offer you unparalleled performance and quality for years of dependable service and listening enjoyment.

SERVICE

Do not attempt to service Precision**Power** products yourself. Performing maintenance on your audio equipment will void the warranty. Many parts of the Precision**Power** product are custom built to our specifications. **Our factory parts are not made available to anyone else nor are they for sale.** Our goal is to make sure that your Precision**Power** product will always sound as good as the day it was purchased. Contact your Authorized Precision **Power** Dealer about obtaining any warranty service through Precision**Power**.

IMPORTANT INFORMATION

Serial # _____

Dealer's Name _____

Date of Purchase _____

Installation Shop _____

Installation Date _____

CAUTION

Extended use of a high powered audio system may result in hearing loss or damage. While Precision**Power** systems are capable of "Concert Level" volumes with incredible accuracy, they are also designed for you to enjoy at more reasonable levels all of the sonic subtleties created by musicians. Please observe all local sound ordinances.

Features

- Full SMT Surface Mount Technology Circuitry
- Double Sided Composite Epoxy PCB
- 2-Ohm Stereo, 4-Ohm Bridged Multi-Channel
- 1-Ohm Stable Class D Monoblock
- Balanced Signal Input (requires BLT)
- Variable 12dB High, Low, & Subsonic Filters
- Band-Pass Crossovers (2ch & 4ch)
- Input Source Selector (4ch & 5ch)
- Variable 12dB 45Hz Bass Boost
- Variable 0-180° Phase Control (1ch & 5ch)
- Dash Mounted Remote Gain Control (1ch & 5ch & BK340.2)
- Direct Wire Power & Speaker Terminals
- Wire Concealing End Caps
- Three-Way Protection Circuitry
- Delayed On/Off Circuit
- Tri-Mode Capable (2/4/5ch models)

SPECIFICATIONS

Load Impedance (1ch) : 1-8 ohms
 Load Impedance (Stereo) : 2-8 ohms
 Load Impedance (Bridged) : 4-8 ohms
 Input Sensitivity : 200mv - 6 Volts RMS
 Input Impedance : 20k Ohms
 Supply Voltage : 9-15 Volts
 Damping Factor : >150
 S/N Ratio : >98dB

12dB Crossovers Type/Range :
 High Pass - 15-4kHz (2/4ch models)
 40-4kHz (5ch model)
 Low Pass - 40-4kHz (2/4/5ch models)
 35-250Hz (1ch model)
 45-450Hz (5ch model)

Power and Fuse Ratings

Model	4 Ohm	2 Ohm	4 Ohm Bridged	1 Ohm	Fuse
BK120.2	40W x 2	60W x 2	120W x 1	/	20A x 1
BK210.2	65W x 2	105W x 2	210W x 1	/	25A x 1
BK340.2	110W x 2	170W x 2	340W x 1	/	25A x 2
BK340.4	55W x 4	85W x 4	170W x 2	/	20A x 2
BK520.4	95W x 4	130W x 4	260W x 2	/	40A x 2
BK800.4	130W x 4	200W x 4	400W x 2	/	30A x 3
BK580.5	55Wx4, 160Wx1	85Wx4, 240Wx1	170Wx2, 240Wx1	/	40A x 2
BK650.1D	240W x 1	450W x 1	/	650W x 1	40A x 2
BK1300.1D	500W x 1	900W x 1	/	1300W x 1	35A x 4
BK1800.1D	700W x 1	1100W x 1	/	1800W x 1	160Ax1(External)

Dimensions

Model	Length	Width	Height
BK120.2	8.8"(224mm)	8.3"(210mm)	2.1"(53mm)
BK210.2	9.6"(244mm)	8.3"(210mm)	2.1"(53mm)
BK340.2	14.3"(364mm)	8.3"(210mm)	2.1"(53mm)
BK340.4	12.4"(314mm)	8.3"(210mm)	2.1"(53mm)
BK520.4	17.3"(439mm)	8.3"(210mm)	2.1"(53mm)
BK800.4	21.0"(534mm)	8.3"(210mm)	2.1"(53mm)
BK580.5	18.3"(464mm)	8.3"(210mm)	2.1"(53mm)
BK650.1D	12.8"(324mm)	8.3"(210mm)	2.1"(53mm)
BK1300.1D	17.1"(434mm)	8.3"(210mm)	2.1"(53mm)
BK1800.1D	19.8"(504mm)	8.3"(210mm)	2.1"(53mm)

Tools/ Parts For Installation



NOTE: TOOLS ARE NOT SUPPLIED

Small Standard screwdriver, Phillips screwdriver (#2 or medium sized), Wire cutters, Wire strippers, - #6 round head screws, and 1 - #8 sheet metal screw (or nut, bolt flat washer, start washer) (see detail), 2 Ring connectors (large enough to accommodate your method of grounding), In-line fuse or circuit breaker.

Built-in Crossover

All Black Ice Series Amplifiers feature built-in electronic crossovers. The Black Ice Series Amplifiers feature continuously-variable low pass crossovers and continuously-variable high pass crossovers, with bandpass options.

Protection Circuitry

The amplifier protection circuitry will disable the amplifier if the inputs are overloaded, short-circuited or extremely high temperature conditions are detected. When the protection mode is in operation, the LED indicator on the front panel will be illuminated, indicating the amplifier has gone into a self-preservation mode.

If you observe that the protection LED is lit, please check the system carefully to determine what has caused the protection circuit to engage. The amplifier can be reset by turning the remote power off and then on again. If the amplifier shuts down due to a thermal overload condition, please allow it to cool down before powering up. If the amplifier shuts down because of an input overload or short circuit, be sure to repair these conditions before attempting to power up the amplifier again.

2 Ohm Operation (in stereo mode)

Your Black Ice Series Amplifier was designed to operate effectively at loads down 2 Ohms. This means that you can install four 8 Ohm speakers per channel when using parallel wiring. Increasing the number of woofers per channel at low frequencies (up to 100Hz) produces an acoustic coupling effect. This acoustic coupling increases your power output by 3 dB per speaker doubling.

When operating at 2 Ohms, the amplifiers will increase their output power by approximately 50%. The current draw will also increase by about the same amount, so be sure you have enough current to run the amplifiers into a 2 Ohm load. If you lack adequate current, your music reproduction will be distorted.

INPUT SENSITIVITY

Please note: The gain control of any car audio amplifier should not be mistaken for a volume control. It is a sophisticated device, designed to match the output level of your audio source unit to the input level of the amplifier. Do not adjust this input level to maximum unless your input level requires it. Ignoring these instructions will result in an input overload to the amplifier, and excessive audio distortion. It can also cause the protection circuit to engage.

Mounting the Amplifier

Mark the location for the mounting screw holes by positioning the amplifier where you wish to install it and use a scribe (or one of the mounting screws) inserted in each mounting hole to mark the mounting surface. If the mounting surface is carpeted, measure the hole centers and mark with a felt tip pen.

Drill pilot holes in the mounting surface for the mounting screws and insert the mounting screws into these holes. Tighten them securely.

Note: Before beginning your installation, be sure to take note of any wires, lines or other devices in your vehicle which may be located behind any mounting surface.

Electrical Wiring

All Black Ice Series Amplifiers are equipped with easy top access screw terminals. These terminals are nickel-plated in order to ensure excellent electrical contact and to resist corrosion.

When making electrical connections to the amplifier, please observe the following:

- Use at least 8 gauge or heavier wire for power and ground connections.
- Wire the amplifier directly to the car battery. Make sure there is circuit protection (Such as a fuse) on the positive power lead, within 18 inches of the battery.
- For the ground connection, use the shortest possible wire to a good chassis ground point.
- Wire the Remote connection to the remote turn-on lead of your equalizer or head unit. In some cases this may be the power antenna lead of the head unit.

FUSING

You will need to install an in-line fuse or circuit breaker in the power wire within 18" of the battery. This fuse or circuit breaker is to protect your vehicle from fire in case the power wire shorts to the vehicle body. If you are only using one amplifier, use the fuse rating indicated in the chart on page 2. If you are using more than one amplifier, add up the fuse ratings for all the amplifiers. This sum is the rating for your fuse or circuit breaker. You may also want to add a power distribution block near your amplifiers to distribute large gauge power cable to multiple amplifiers.

REMOTE GAIN CONTROL

The Black Ice Series BK340.2, BK580.5, BK650.1D, BK1300.1D & BK1800.1D are equipped with a dashboard mount remote subwoofer level control. Run the supplied dashboard remote control from the front panel of your amplifier. By turning the level knob clockwise, you will increase the output of low frequencies.

PANEL LAYOUT

BK120.2

LEFT VIEW

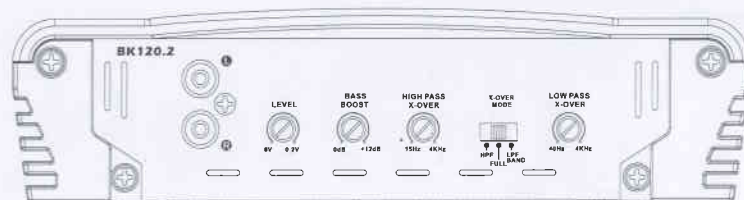

RIGHT VIEW

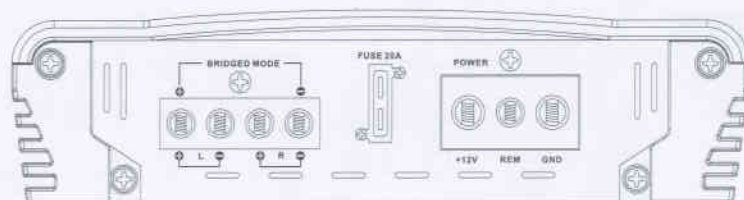

PANEL LAYOUT

BK210.2

LEFT VIEW



RIGHT VIEW

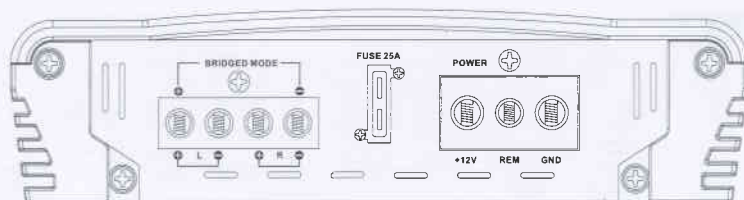

PANEL LAYOUT

BK340.2

LEFT VIEW

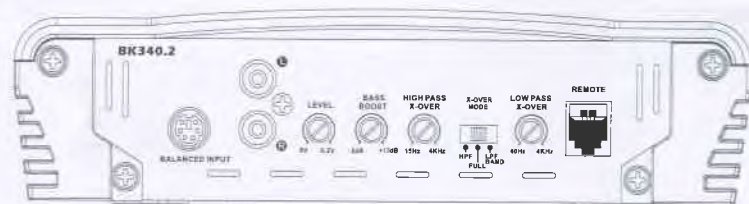

RIGHT VIEW

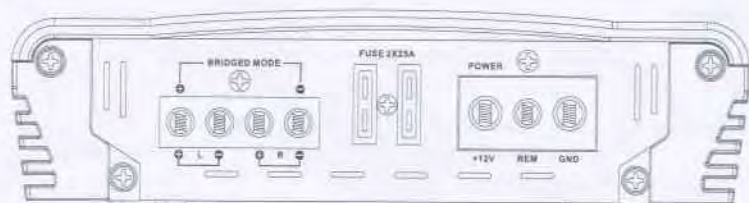

PANEL LAYOUT

BK340.4

LEFT VIEW

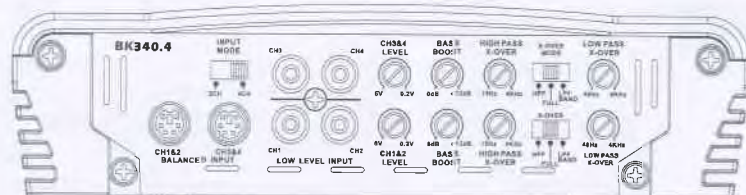

RIGHT VIEW

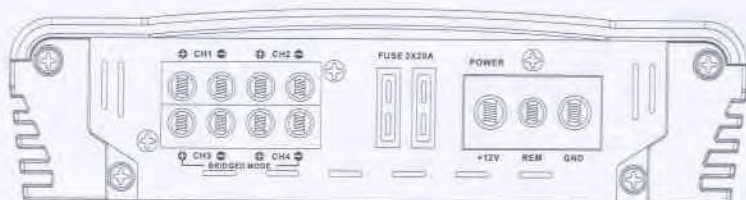

PANEL LAYOUT

BK520.4

LEFT VIEW

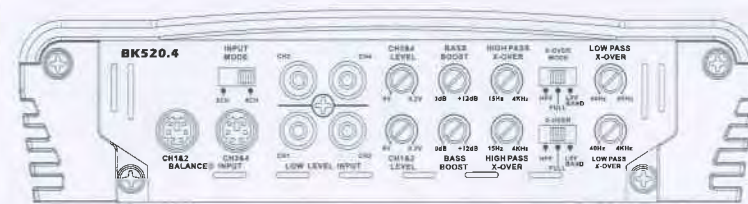

RIGHT VIEW

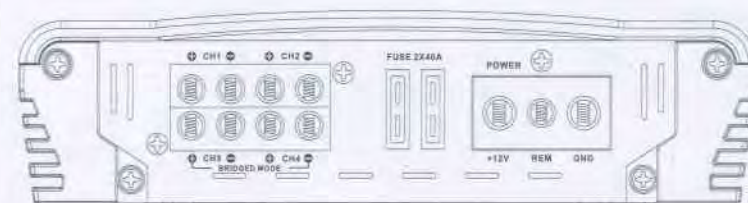

PANEL LAYOUT

BK800.4

LEFT VIEW

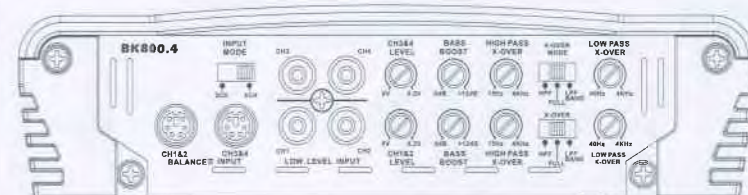

RIGHT VIEW

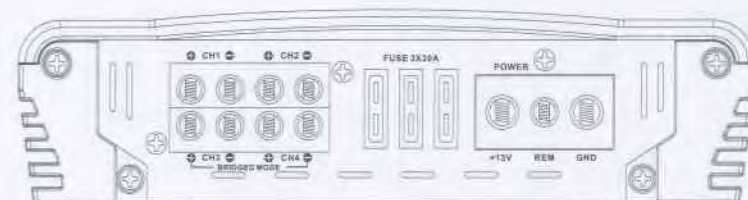

PANEL LAYOUT

BK580.5

LEFT VIEW

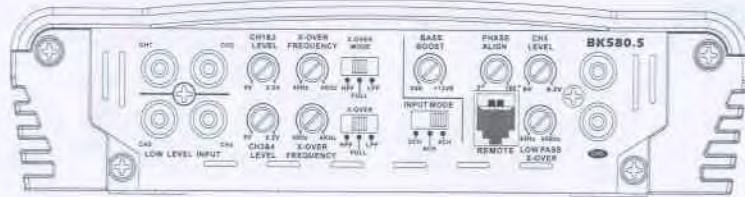

RIGHT VIEW

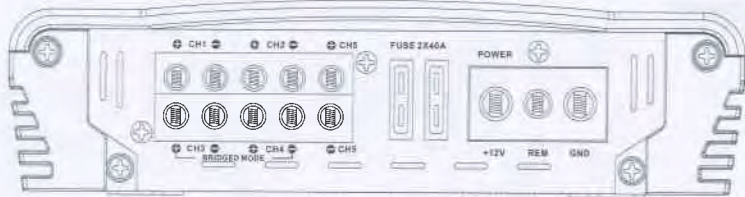

PANEL LAYOUT

BK1300.1D

LEFT VIEW

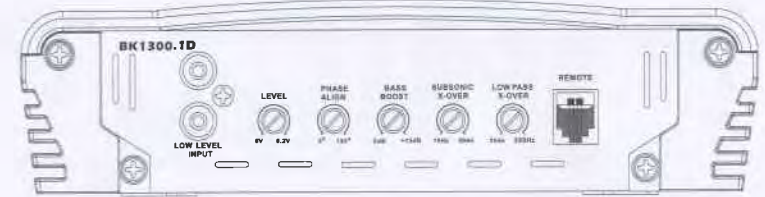

RIGHT VIEW

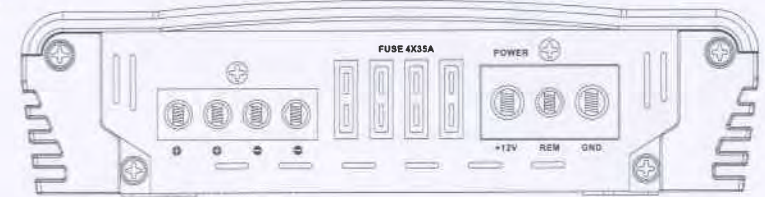

PANEL LAYOUT

BK650.1D

LEFT VIEW

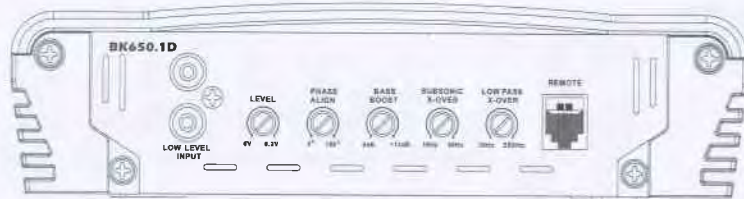

RIGHT VIEW

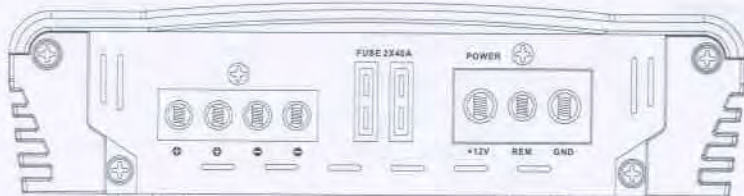

PANEL LAYOUT

BK1800.1D

LEFT VIEW

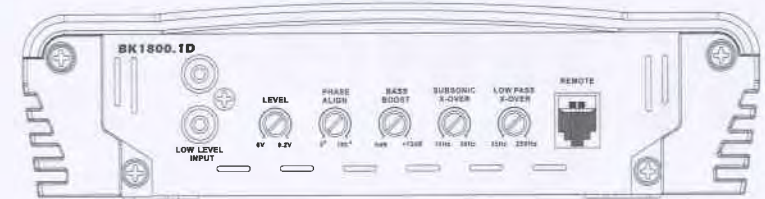

RIGHT VIEW

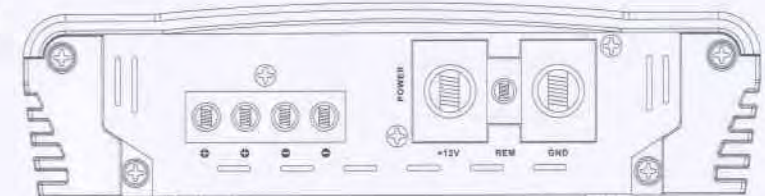

Balanced Inputs

BK210.2

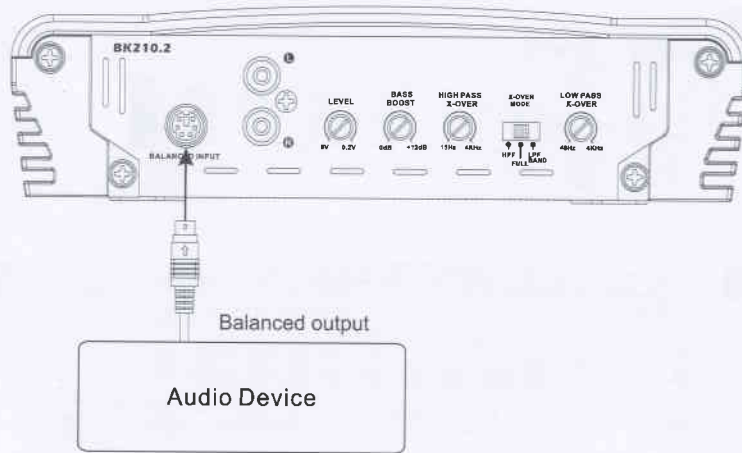

Balanced Inputs

BK340.4 / BK520.4 / BK800.4

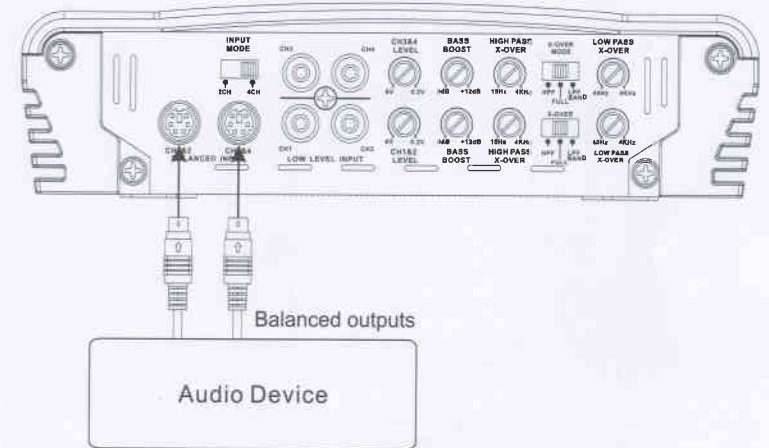

BK340.2

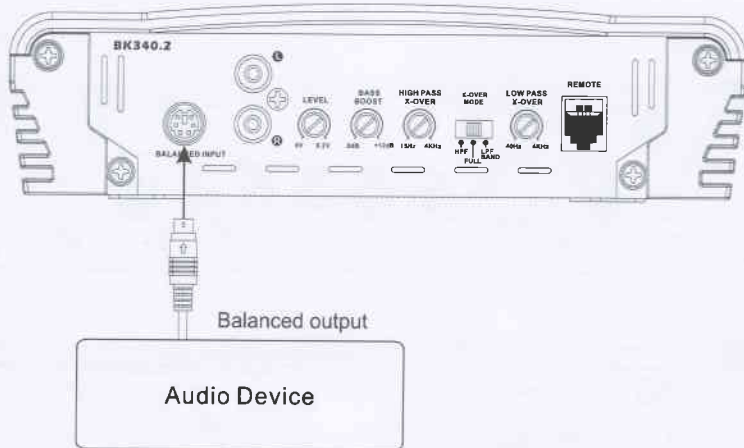

Low Level Inputs

BK120.2

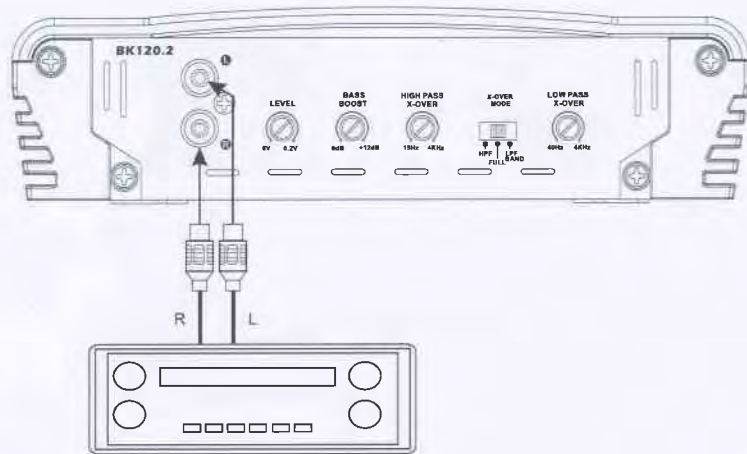

BK210.2

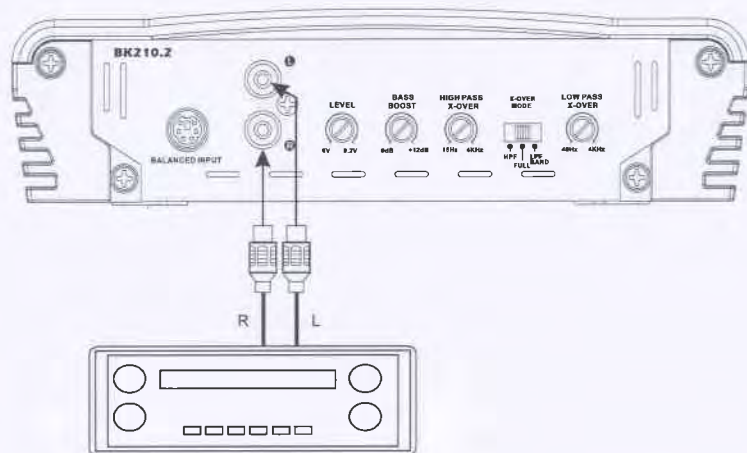

Low Level Inputs

BK340.2

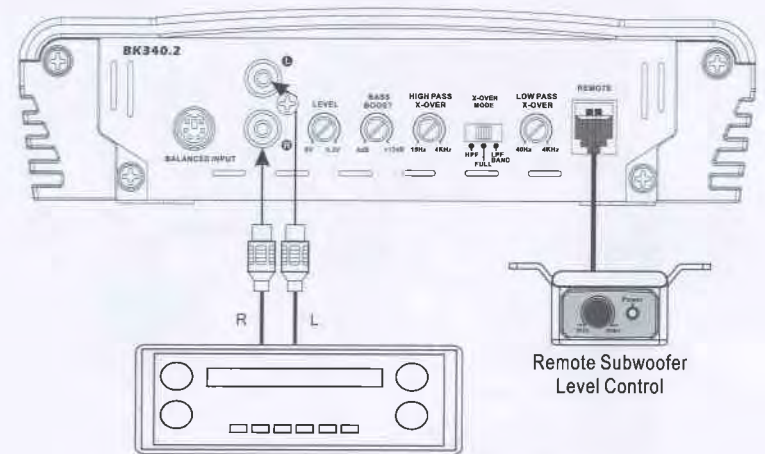

BK340.4 / BK520.4 / BK800.4

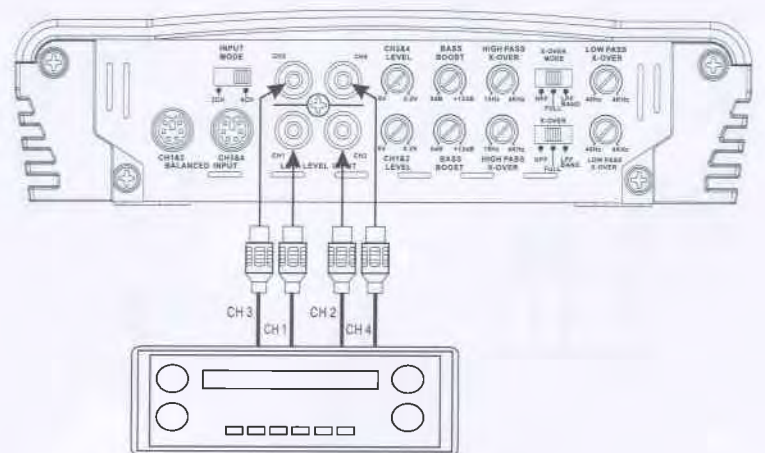

Low Level Inputs

BK580.5

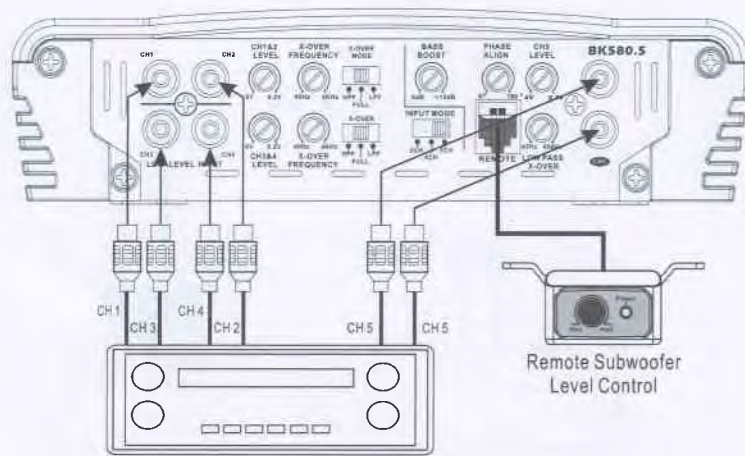

BK650.1D / BK1300.1D / BK1800.1D

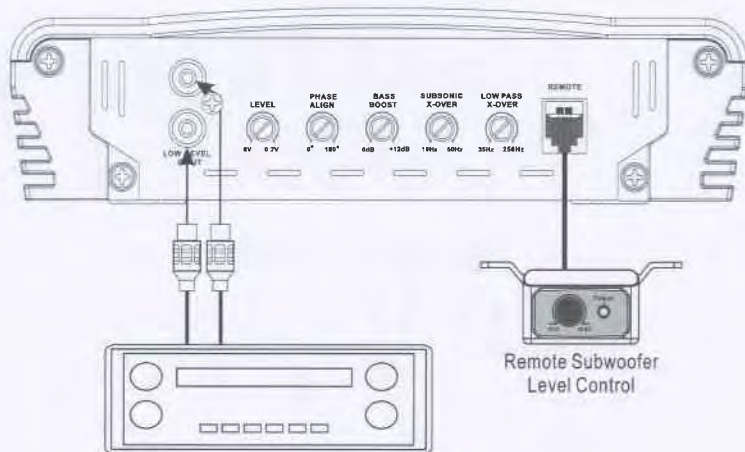

Speakers Connections

2 CHANNEL STEREO

BK120.2 / BK210.2 (use 1 fuse)
BK340.2 (use 2 fuses)

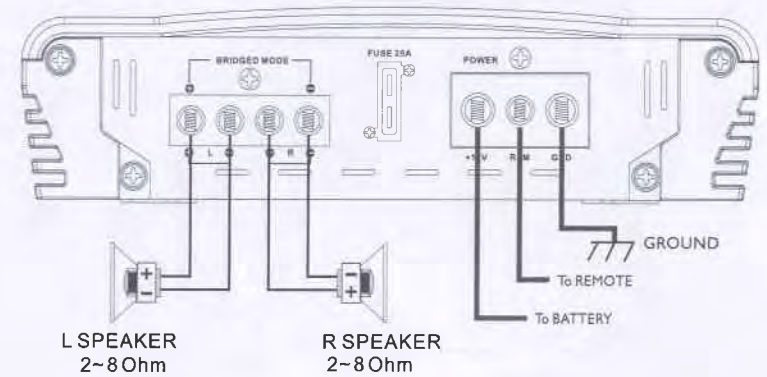

2 CHANNEL BRIDGED

BK120.2 / BK210.2 (use 1 fuse)
BK340.2 (use 2 fuses)

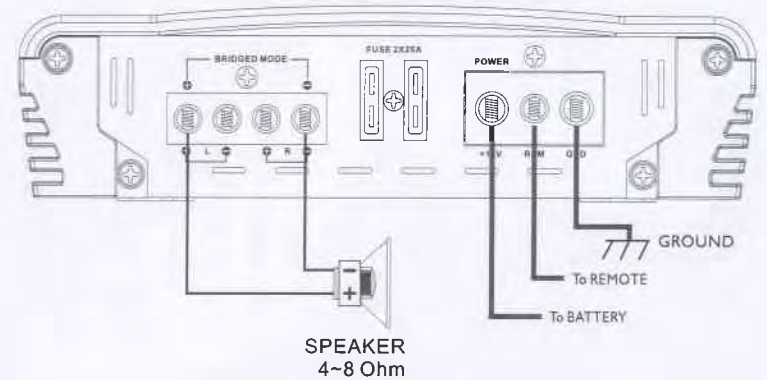

Speakers Connections

4 CHANNEL STEREO

BK340.4 / BK520.4 (use 2 fuses)
BK800.4 (use 3 fuses)

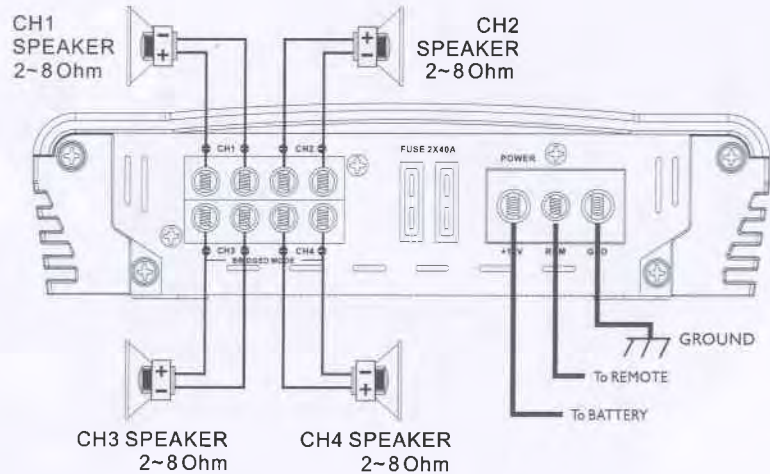

4 CHANNEL BRIDGED

BK340.4 / BK520.4 (use 2 fuses)
BK800.4 (use 3 fuses)

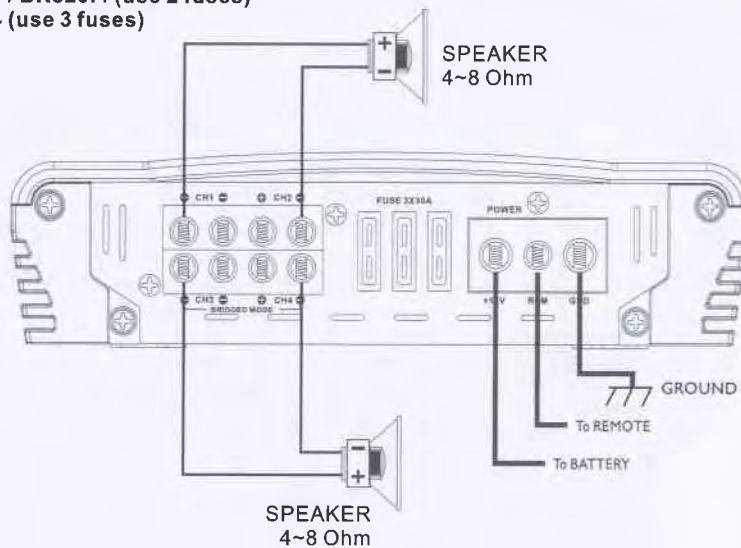

Speakers Connections

5 CHANNEL STEREO

BK580.5

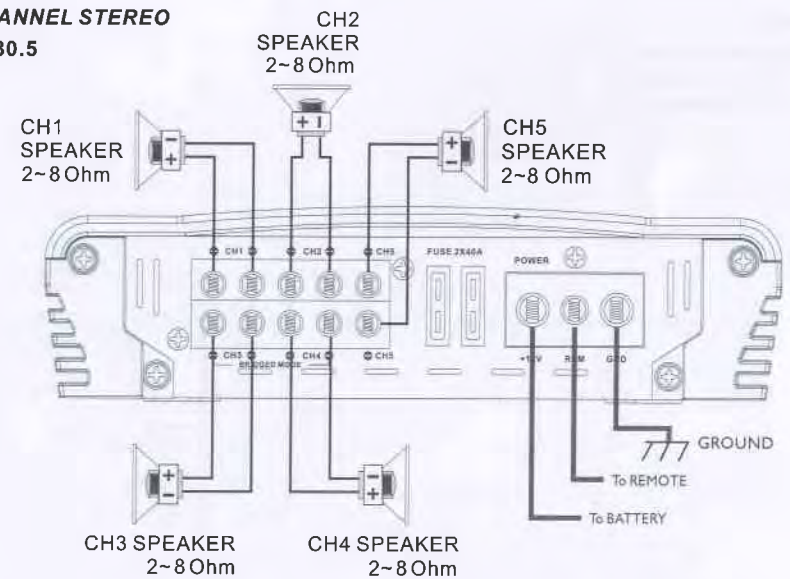

5 CHANNEL BRIDGED

BK580.5

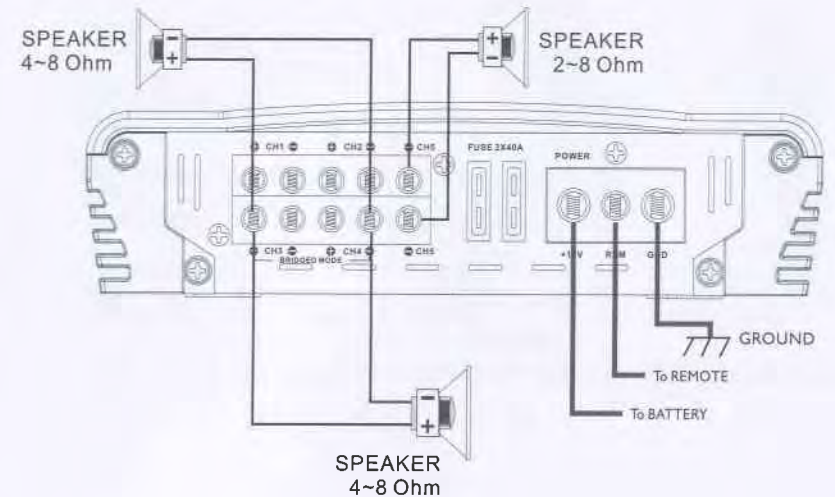

Speakers Connections

1 CHANNEL

BK650.1D (use 2 fuses)
 BK1300.1D (use 4 fuses)
 BK1800.1D (External fuse)

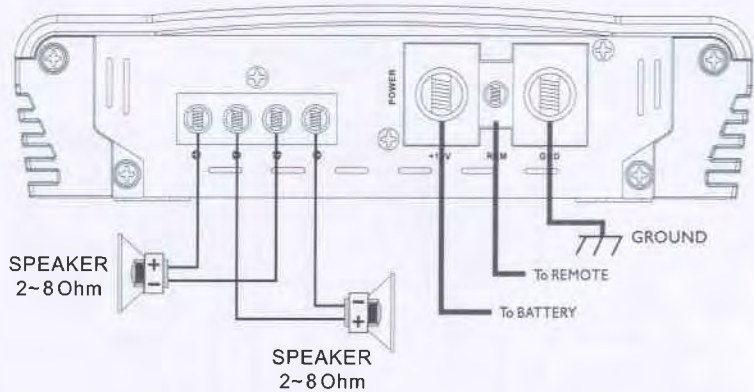
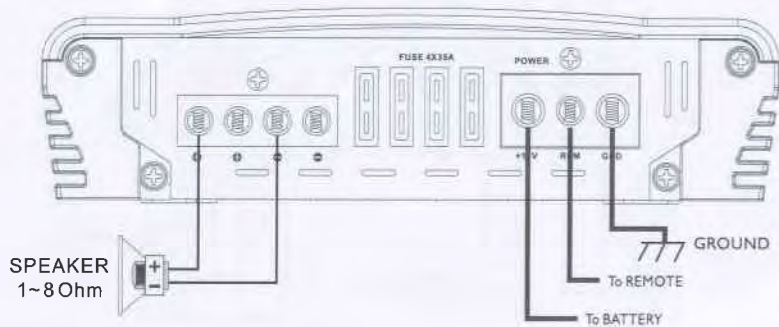

TROUBLE SHOOTING

NO SOUND

Is the LED lit?

YES

NO

Check Power and Remote turn-on wire for voltage. Make sure Ground wire is secure.

STILL NO SOUND

See your Authorized Sound Stream Dealer.

SOUND IN ONE CHANNEL ONLY

Reverse left and right speakers by unplugging the speaker connector, turning it over and plugging it back in.

SOUND IS NOW ON

OPPOSITE CHANNEL

Reverse RCA inputs

SAME CHANNEL

Problem is in the speaker or speaker wire of the silent channel

SOUND IS NOW ON

OPPOSITE CHANNEL

Reverse RCAs at head unit

SAME CHANNEL

Problem is in the Amplifier, See your local Authorized Dealer

SOUND IS NOW ON

OPPOSITE CHANNEL

Problem is in the head unit or before the amplifier

SAME CHANNEL

Problem is in the RCA cables

PROTECTION CIRCUIT

Short Circuit Protection engaged: The amplifier will turn off immediately. If this is the case, check your speakers and wiring for low impedance and short circuits, reset on the amplifier when you are sure that no such problem occurs.

Thermal Protection engaged: The amplifier will turn off and several minutes later will come back on. In this case, ensure that there is nothing blocking the normal convective airflow of the amplifier. No obstruction should be within 2" of the amplifier on all sides.

NOTE: Low battery voltage will cause the amplifier to run warmer and possibly damage the amplifier.